

**PLAN NOTES:**

- THIS PLOT PLAN IS PREPARED FROM LINES OF OCCUPATION. THE TIES TO THE LOT LINES ARE NOT TO BE USED IN THE SETTING OF FENCES, HEDGES, ETC. AND IS NOT TO BE CONSIDERED A PROPERTY LINE SURVEY.

**SCHEDULE OF ELEVATIONS**

TOP OF FOUNDATION T.C. =	198.89
BASEMENT FLOOR FIN. C.F. =	195.54
INVERT OF PIPE AT FOUNDATION =	UNDER C.F.
INVERT AT SEPTIC TANK INLET =	193.5±
INVERT AT SEPTIC TANK OUTLET =	193.3
INVERT AT PUMP TANK INLET =	193.1
INVERT AT PUMP TANK OUTLET =	192.9
INVERT AT DISTRIBUTION BOX INLET =	197.3
INVERT AT DISTRIBUTION BOX OUTLET =	197.1
INVERT AT LEACHING LINES (BEGINNING) =	196.9
INVERT AT LEACHING LINES (END) =	196.7
ELEVATION OF BED BOTTOM =	196.2
FINISH GRADE OVER LEACHING AREA =	199-198±

**DESIGN CRITERIA**

- ESTIMATED FLOW = 2 BDRMS X 110 GPD/BR=220 GPD
- DESIGN PERCOLATION RATE = 10 MPI
- LEACHING AREA CALCULATION = SIZED FOR 3 BEDROOM MINIMUM SIZING.

BED AREA = 18.5 x 30 = 555 SF(0.6 GPD/SF)=333 GPD

**PUMP NOTES:**

- THE PUMP CHAMBER SHALL BE A 1,000 GALLON SEPTIC TANK AS PRODUCED BY: E.F. SHEA INC. OR ITS APPROVED EQUAL. ALL JOINTS SHALL BE MORTARED, AND THE TANK WATER TIGHT.
- THE PUMP SHALL BE A MYERS 4/10 HP PUMP OR EQUAL WITH A 2" INCH DISCHARGE LINE AND SHALL BE EQUIPPED WITH 115 VOLT SINGLE PHASE POWER, 5M 15NO FLOATS, AND A CE 115 CONTROL PANEL THAT IS EQUIPPED WITH AN AUDIBLE ALARM.
- HIGH WATER ALARM TO CONSIST OF A MERCURY FLOAT SWITCH (CE 115 ALARM CONTROL) WITH A POWER CIRCUIT SEPARATE OF THE PUMP POWER CIRCUIT, SET TO ACTIVATE ALARM IN THE HOUSE WHEN WATER REACHES THE ELEVATION OF 191.1
- ALL WIRING TO BE PLACED OUTSIDE OF HOUSE TO BE WATERPROOF AND INSTALLED ACCORDING TO APPLICABLE CODES.
- THE DISTRIBUTION BOX SHALL BE EQUIPPED WITH A TEE.
- ANY BAFFLE OR TEE THAT OBSTRUCTS THE DISCHARGE LINE SHALL BE REMOVED.
- THE ALARM IS TO HAVE AN ALTERNATIVE SUPPLY IN CASE OF POWER FAILURE.
- WEEPHOLE MUST BE IN 2" INCH FORCE MAIN. THE HOLE SHOULD BE LOCATED BETWEEN THE CHECK VALVE AND INSIDE OF TANK.
- CONTROL PANEL TO BE EQUIPPED WITH ON-OFF AND MANUAL SWITCHING POSITIONS.
- CHECK VALVE SHALL BE OF BALL TYPE, INSTALLED VERTICALLY WITH A 3/8" WEEP LOCATED ON THE DISCHARGE SIDE OF THE CHECK VALVE BETWEEN WAFFLE AND INSIDE WALL OF TANK.
- ALL PRESSURE PIPING SHALL BE SECURED AND SHIELDED FROM ABRASION, AND SHALL BE COUPLED WITH HIGH PRESSURE PVC COUPLINGS.

**TOTAL DYNAMIC HEAD CALCULATION:**

LINEAL FEET OF 2 INCH PIPE =	10
EQUIVALENT FEET OF PIPE FOR FITTINGS =	41
TOTAL LINEAL FEET OF PIPE =	51
FRICTION HEAD LOSS PER 100' AT 55 GPM =	4.8
STATIC HEAD =	7.7
EQUIVALENT HEAD = 51 / 100 x 4.8 =	2.4
TOTAL DYNAMIC HEAD =	10.1

**PUMP DISCHARGE CALCULATIONS**

DOSE(S) PER DAY = 2 DOSES  
 1000 GAL. TANK = 4.7 x 7.5 x 1 x 7.48 GAL./C.F. = 263.6 GAL./DOSE  
 PUMP CAPACITY AT 10.1 FT. OF HEAD = 55 GAL. / MIN.  
 DOSE TIME = 236.6 / 55 = 4.3 MIN. / DOSE

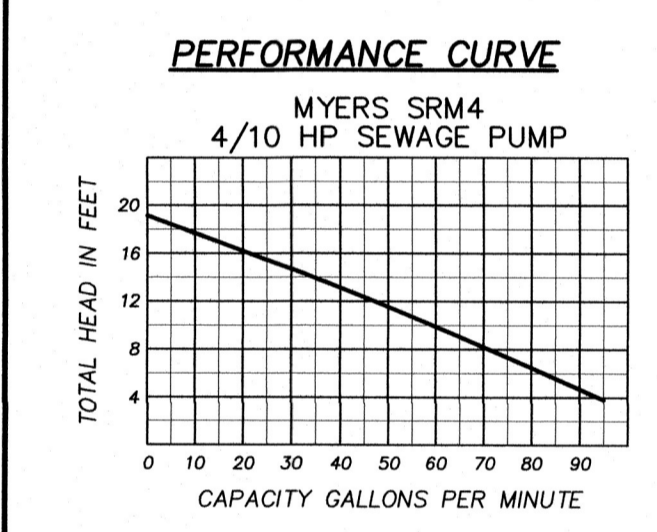
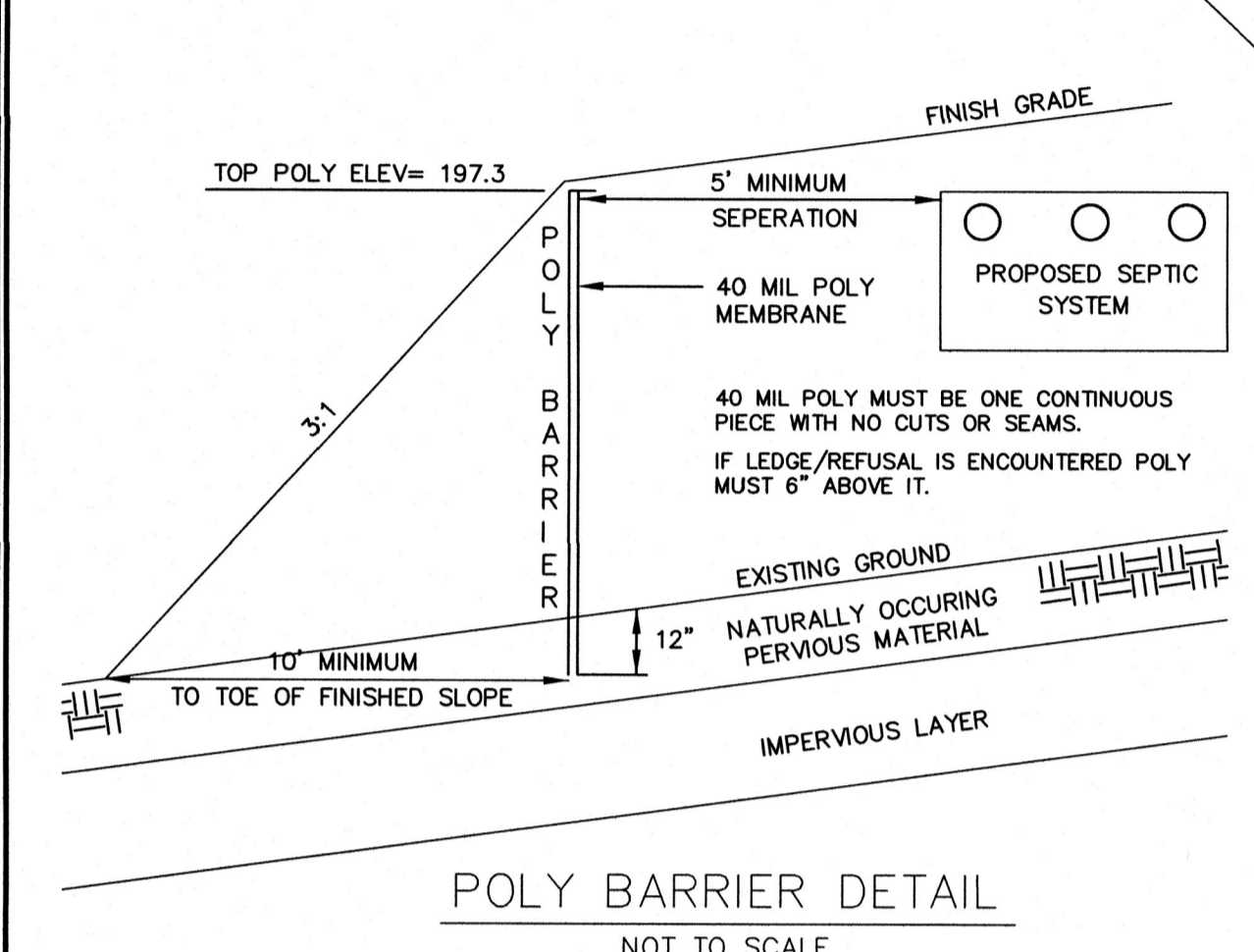

**TANK SIZING:**

3 BEDROOMS = 330 GPD  
 TWO COMPARTMENT TANK  
 FIRST COMPARTMENT=2 DAYS STORAGE=660 GPD  
 SECOND COMPARTMENT=1 DAY STORAGE=330 GPD  
 990 GPD REQUIRED. 1,500 GPD PROVIDED

**LOCAL UPGRADE APPROVALS REQUIRED:**

- COVER OVER LEACH TANKS GREATER THAN 3 FEET (4' PROPOSED).
- LEACH BED SEPARATION TO E.S.H.G.W. LESS THAN 4' (3' PROPOSED).
- WELL SEPARATION TO LEACH BED LESS THAN 100' (77' PROPOSED).
- LEACH BED SEPARATION TO FOUNDATION LESS THAN 20' (12' PROPOSED).

**WELL LOCATION VARIANCES REQUIRED:**

- WELL LOCATION LESS THAN 35' TO PROPERTY LINES (13' PROPOSED).
- WELL LOCATION LESS THAN 50' TO A PUBLIC WAY (13' PROPOSED).
- WELL SEPARATION TO LEACH BED LESS THAN 100' (77' PROPOSED).

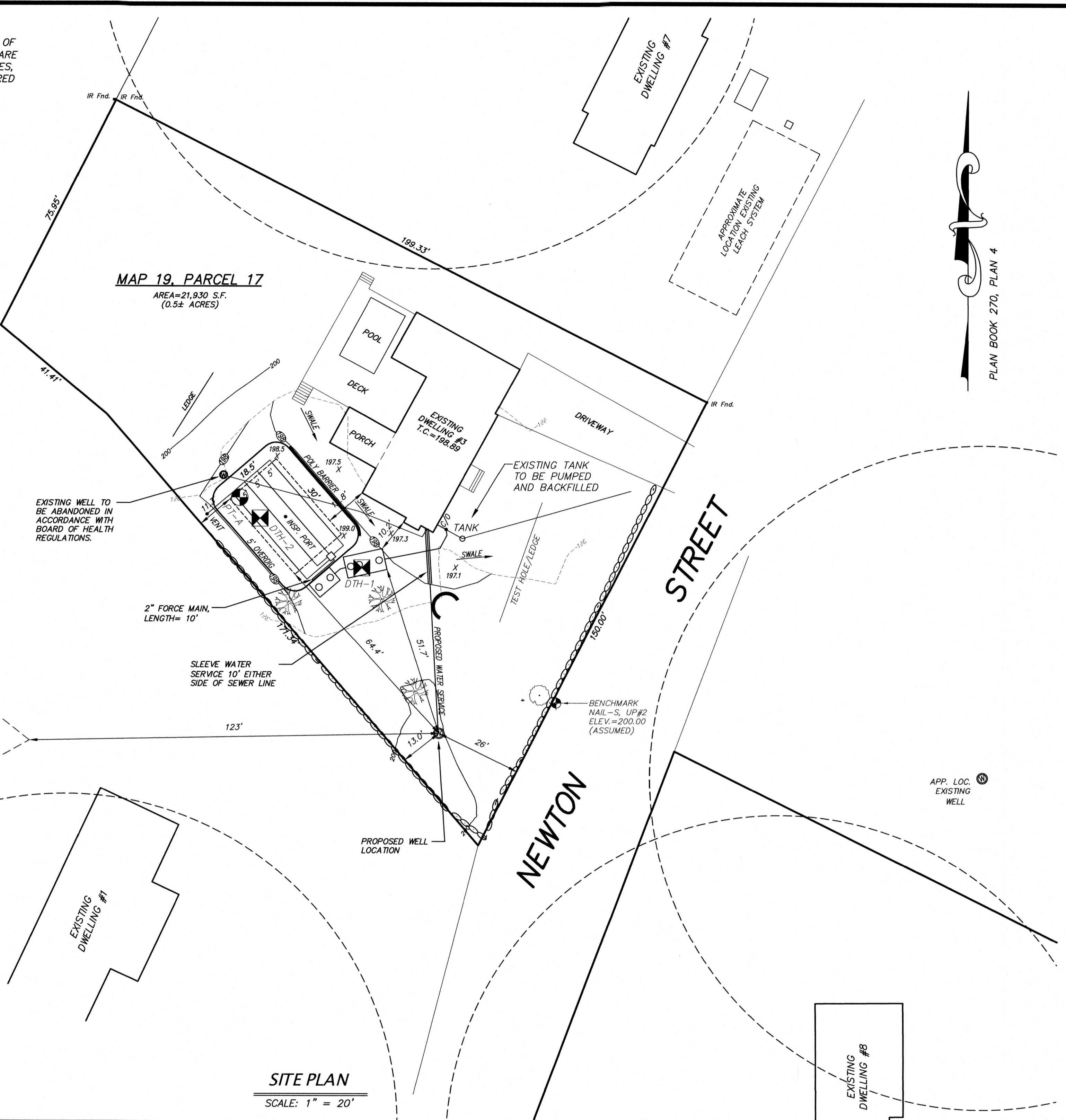

**GENERAL NOTES:**

- Contractor shall call Digsafe at (888) 344-7233 a minimum of 72 hours prior to commencing any construction activities on site.
- Inspections by Design Engineer and Board of Health are as required by the Board of Health.
- This plan was prepared for the design of the subsurface sewage disposal system only and is based on the subsurface exploration and percolation tests listed below.
- System was designed only to accommodate sanitary sewage associated with normal domestic usage, consisting of water carried putrescible waste, and for flows indicated in the design criteria.
- The system must be vented through the buildings plumbing in accordance with the state building code.
- Plans show only features that were visually apparent on the date of the topographic survey, and the absence of subsurface structures, utilities, etc. is not guaranteed.
- Contractor to determine if site conditions are suitable for construction of proposed system, and must promptly notify the Design Engineer and Owner, in writing, of any plan deficiencies, unforeseen subsurface conditions, or required changes.
- There are no wells located within 100 feet of the proposed leaching area or within 100 feet of the proposed septic tank (except as shown).
- The subject property is not located within a Zone II of a public drinking water supply well.
- All construction is to conform to the requirements of the Massachusetts Environmental Code, Title V, and the town of NORTHBOROUGH, Board of Health regulations.
- There are no bordering vegetated wetlands, inland banks, or surface waters within 100' of the proposed system.
- There are no surface or subsurface drains which are used to lower the ground water.
- All elevations refer to TBM, NAIL-S, UP#2, ELEV=200.
- For proper performance, septic tank should be pumped annually.
- System cannot be backfilled or concealed until design firm and board of health have inspected the system and permission to backfill has been given.
- Design firm must prepare and submit "As-Built" plan to Board of Health. This plan must certify that the system was installed in accordance with state and local regulations and that it complies with the proposed plan.
- Property lines are approximate and are not to be used for boundary survey purposes. Surface features and topography outside of work area are approximate.
- System is not designed to accommodate a garbage grinder.

**TECHNICAL NOTES:**

- Building sewer shall be in accordance with state plumbing code and have a minimum of 4" of cover in landscaped areas. A minimum of 12" of cover and/or appropriate sleeving shall be used in areas subject to vehicular traffic.
- All tanks, including septic tanks, distribution boxes, dosing chambers, and grease traps shall be either watertight through manufacturer's specification and warranty, or made watertight by the manufacturer or other individual by means and persons as approved in 310 CMR 15.221. Septic tank shall be constructed and placed in accordance with 310 CMR 15.223 through 310 CMR 15.228.
- Septic tanks shall have at least three (3) 20" manholes with at least one (1) of these manholes located no more than 6" below finish grade. (Systems over 1,000 gpd shall have access ports at both the inlet and outlet tees.)
- Distribution box ("d-box") shall be of watertight construction, installed level on a firm base, and installed in accordance with 310 CMR 15.232.
- Septic tank covers and d-box are to be brought within 6" and 9" of finish grade respectively by the use of riser sections.
- When the SAS is installed within the top and subsoil layers or above natural grade, all topsoil and subsoil shall be removed below and laterally a minimum of 5 feet surrounding the SAS. Removed material shall be replaced with clean granular material in accordance with 310 CMR 15.255(3).
- All disturbed areas shall be loamed, seeded, and maintained so as to prevent erosion.
- All native soil interfaces which will contact the SAS shall be scarified prior to placement of stone.

**PERCOLATION TESTS**

HOLE NO. & DATE	TOP ELEVATION	DEPTH (In.)	SATURATION (Min.)	12"-9" DROP (Min.)	9"-6" DROP (Min.)	PERC. RATE (Min./In.)
PT-A 03/07/23	197.1	66"	15 MIN	16 MIN	27 MIN	9 MIN/IN

**DEEP OBSERVATION HOLE LOG**

NO., DATE & ELEV.	DEPTH (In.)	SOIL HORIZON	TEXTURE (USDA)	COLOR (MUNSELL)	SOIL MOTTLING	OTHER
DTH-1	0-10"	Ap	SANDY LOAM	10YR3/2		
03/07/23	10-35"	Bw	SANDY LOAM	10YR5/6		
196.8	35-85"	C	LOAMY SAND	2.5Y5/4	ø 46"	COBBLES/STONES 25X

DEPTH TO BEDROCK: - STANDING WATER: 66" WEEPING FROM PIT FACE: - ESHWT: 193.0

DEPTH TO BEDROCK: - STANDING WATER: - WEEPING FROM PIT FACE: - ESHWT: 193.2

TESTS CONDUCTED BY: VITO COLONNA  
 TESTS OBSERVED BY: KRISTIN BLACK DATE: 03/07/2023

I certify that I have passed the examination approved by the department of Environmental Protection and that the above analysis has been performed by me consistent with the required training, expertise, and experience described in 310 CMR 15.018(2).

*Vito Colonna* Certified: 2011

**SEPTIC TANK NOTES:**

- MUST BE WATER TIGHT AND SET ON A LEVEL BASE THAT HAS BEEN COMPACTED TO PREVENT SETTLING.
- TANK MUST HAVE A SEAL STATING THAT ASTM STANDARDS HAVE BEEN MET.

THREE 20" MANHOLES WITH READILY REMOVABLE IMPERMEABLE COVERS OF DURABLE MATERIAL

IF A FILTER IS INSTALLED: BRING COVER OVER FILTER TO FINISH GRADE. MAINTAIN FILTER PER MANUFACT. SPECS./APPROVAL

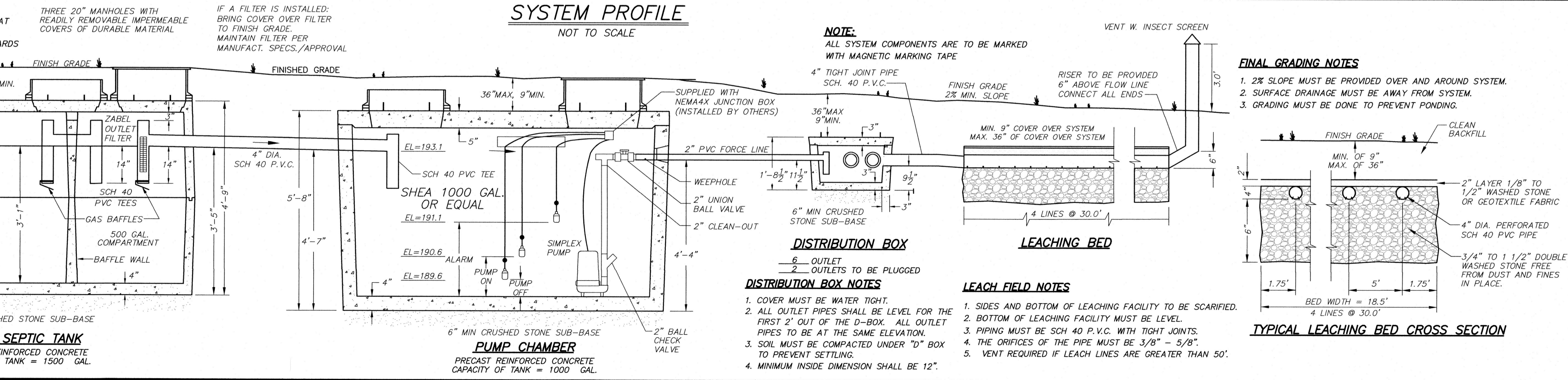

**OWNER**  
NO LIMIT ASSETS, LLC

**LOCATION**  
3 NEWTON STREET  
NORTHBOROUGH, MA  
ASSESSORS MAP 17 & PARCEL 19

NO.	DATE	REVISION	BY
1.	1/24/2024	REVISED WELL LOCATION	REM

**PROPOSED SEWAGE DISPOSAL SYSTEM**

**CONNORSTONE ENGINEERING**  
CONSULTING CIVIL ENGINEERS AND LAND SURVEYORS  
10 SOUTHWEST CUTOFF, SUITE 7  
NORTHBOROUGH, MASSACHUSETTS 01532  
PHONE: 508-393-9727 WWW.CSEI.NET

121 BOSTON POST RD. SUDBURY, MA. 01776  
PHONE: 978-443-9566 WWW.SULLIVANCONNORS.COM

DATE: 03/09/23 SHEET 1 OF 1