



NORSE ENVIRONMENTAL SERVICES, INC.

92 Middlesex Road, Unit 4

Tyngsboro, MA 01879

TEL. (978) 649-9932 • FAX (978) 649-7582

Website: www.norseenvironmental.com

February 1, 2021

Northborough Conservation Commission
Northborough Town Hall
63 Main Street
Northborough, MA 01532

RE: Notice of Intent, 0 Hudson Street, Northborough, MA

Dear Northborough Conservation Commission:

Norse Environmental Services, Inc. is pleased to submit this Notice of Intent (NOI) on behalf of the applicant, Circle Assets, LLC for the construction of two duplexes at 0 Hudson Street (Assessors Map 53 Lot 19, 20, 21) in Northborough, MA. This NOI is a joint filing under the MA Wetlands Protection Act (the WPA) and the Town of Northborough Wetlands Protection Bylaw (the Bylaw). A portion of the subject parcel (part of what is referred to as Lot 1) was subject to a now expired Superseding Order of Conditions for the construction of a duplex under DEP File #247-0953. That project is substantially similar to the previously proposed and approved Lot #1.

The original and 2 copies of the NOI application are enclosed, along with full size site plans. The titles of all the documents enclosed are as follows:

- NOI (WPA Form 3) Application Form
- NOI Wetland Fee Transmittal Form
- Copy of Fee Checks
- Affidavit of Service, Abutters List, Notification to Abutters
- *Regulatory Discussion*, Norse Environmental Services, Inc., 1/26/2021
- *Waiver Request*, Norse Environmental Services, Inc., 1/26/2021
- *Wetland Replication, Compensatory Storage and Invasive Species Management Plans*, Norse Environmental Services, Inc., 1/26/2021
- *Wetland Border Report*, Norse Environmental Services, Inc. 8/18/2019
- *USGS Site Locus*, 4/18/2018
- *Ortho Site Locus*, 4/18/2018
- *Wildlife Habitat Evaluation*, Norse Environmental Services, Inc., 1/26/2021
- *Figures 1-4*, Norse Environmental Services, Inc., 8/18/2019
- *Plan of 0 Hudson Street in Northborough, MA* (3 sheets), Connorstone Engineering, 12/24/2020
- *Alternative Site Plan of 0 Hudson Street in Northborough, MA*, Connorstone Engineering, 12/24/2020

Please feel free to contact us if you have any questions.

Very truly yours,

Steve Eriksen, Professional Wetland Scientist
Norse Environmental Services, Inc.

CC: CERO-DEP, Wetlands Division, 8 New Bond Street, Worcester, MA 01606
Circle Assets, LLC, 291 Main Street, Suite 8, Northborough, MA 01532

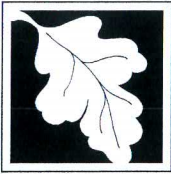

WPA Form 3 – Notice of Intent

Massachusetts Wetlands Protection Act M.G.L. c. 131, §40
& Northborough Wetlands Protection Bylaw & Regulations

MassDEP File Number

Document Transaction Number

Northborough

City/Town

Important:
When filling out forms on the computer, use only the tab key to move your cursor - do not use the return key.

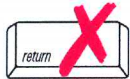

Note:
Before completing this form consult your local Conservation Commission regarding any municipal bylaw or ordinance.

A. General Information

1. Project Location (**Note:** electronic filers will click on button to locate project site):

0 Hudson Street	Northborough	01532
a. Street Address	b. City/Town	c. Zip Code
Latitude and Longitude:	42.331260	71.629760
	d. Latitude	e. Longitude
Map 53	Lots 19, 20, 21	
f. Assessors Map/Plat Number	g. Parcel /Lot Number	

2. Applicant:

Scott	Goddard	
a. First Name	b. Last Name	
Circle Assets LLC		
c. Organization		
291 Main Street Suite 8		
d. Street Address		
Northborough	MA	01532
e. City/Town	f. State	g. Zip Code
(508) 393-3784	scott@goddardconsultingllc.com	
h. Phone Number	i. Fax Number	j. Email Address

3. Property owner (required if different from applicant): Check if more than one owner

_____	_____	
a. First Name	b. Last Name	

c. Organization		

d. Street Address		
_____	_____	_____
e. City/Town	f. State	g. Zip Code
_____	_____	_____
h. Phone Number	i. Fax Number	j. Email address

4. Representative (if any):

Steve	Eriksen	
a. First Name	b. Last Name	
Norse Environmental Services, Inc.		
c. Company		
92 Middlesex Road – Unit 4		
d. Street Address		
Tyngsboro	MA	01879
e. City/Town	f. State	g. Zip Code
978-649-9932	noreseenvironmental@verizon.net	
h. Phone Number	i. Fax Number	j. Email address

5. Total WPA Fee Paid (from NOI Wetland Fee Transmittal Form):

\$2,625	\$1,300	\$1,325 (+\$200 bylaw fee)
a. Total Fee Paid	b. State Fee Paid	c. City/Town Fee Paid

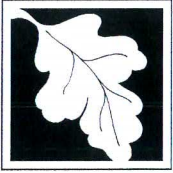

WPA Form 3 – Notice of Intent

Massachusetts Wetlands Protection Act M.G.L. c. 131, §40
& Northborough Wetlands Protection Bylaw & Regulations

MassDEP File Number

Document Transaction Number

Northborough

City/Town

A. General Information (continued)

6. General Project Description:

The construction of two duplexes with associated appurtenances and a constructed wetland replication area and BLSF compensatory Storage.

7a. Project Type Checklist: (Limited Project Types see Section A. 7b.)

- 1. Single Family Home
- 2. Residential Subdivision
- 3. Commercial/Industrial
- 4. Dock/Pier
- 5. Utilities
- 6. Coastal engineering Structure
- 7. Agriculture (e.g., cranberries, forestry)
- 8. Transportation
- 9. Other

7b. Is any portion of the proposed activity eligible to be treated as a limited project (including Ecological Restoration Limited Project) subject to 310 CMR 10.24 (coastal) or 310 CMR 10.53 (inland)?

- 1. Yes No If yes, describe which limited project applies to this project. (See 310 CMR 10.24 and 10.53 for a complete list and description of limited project types)

2. Limited Project Type

If the proposed activity is eligible to be treated as an Ecological Restoration Limited Project (310 CMR 10.24(8), 310 CMR 10.53(4)), complete and attach Appendix A: Ecological Restoration Limited Project Checklist and Signed Certification.

8. Property recorded at the Registry of Deeds for:

Worcester

a. County

58764

c. Book

b. Certificate # (if registered land)

32

d. Page Number

B. Buffer Zone & Resource Area Impacts (temporary & permanent)

- 1. Buffer Zone Only – Check if the project is located only in the Buffer Zone of a Bordering Vegetated Wetland, Inland Bank, or Coastal Resource Area.
- 2. Inland Resource Areas (see 310 CMR 10.54-10.58; if not applicable, go to Section B.3, Coastal Resource Areas).

Check all that apply below. Attach narrative and any supporting documentation describing how the project will meet all performance standards for each of the resource areas altered, including standards requiring consideration of alternative project design or location.

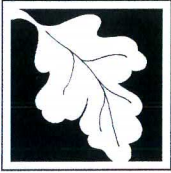

WPA Form 3 – Notice of Intent

Massachusetts Wetlands Protection Act M.G.L. c. 131, §40
& Northborough Wetlands Protection Bylaw & Regulations

MassDEP File Number _____

Document Transaction Number _____

Northborough _____

City/Town _____

B. Buffer Zone & Resource Area Impacts (temporary & permanent) (cont'd)

For all projects affecting other Resource Areas, please attach a narrative explaining how the resource area was delineated.

Resource Area	Size of Proposed Alteration	Proposed Replacement (if any)
a. <input type="checkbox"/> Bank	1. linear feet _____	2. linear feet _____
b. <input checked="" type="checkbox"/> Bordering Vegetated Wetland	520 1. square feet _____	800 2. square feet _____
c. <input type="checkbox"/> Land Under Waterbodies and Waterways	1. square feet _____ 3. cubic yards dredged _____	2. square feet _____

Resource Area	Size of Proposed Alteration	Proposed Replacement (if any)
d. <input checked="" type="checkbox"/> Bordering Land Subject to Flooding	21,470 1. square feet _____ 7,552 3. cubic feet of flood storage lost _____	21,288 2. square feet _____ 9,131 4. cubic feet replaced _____
e. <input type="checkbox"/> Isolated Land Subject to Flooding	1. square feet _____ 2. cubic feet of flood storage lost _____	3. cubic feet replaced _____
f. <input checked="" type="checkbox"/> Riverfront Area	Assabet River (inland) 1. Name of Waterway (if available) - specify coastal or inland _____	

2. Width of Riverfront Area (check one):

25 ft. - Designated Densely Developed Areas only

100 ft. - New agricultural projects only

200 ft. - All other projects

3. Total area of Riverfront Area on the site of the proposed project: 72,588
square feet

4. Proposed alteration of the Riverfront Area:

<u>4,960</u>	<u>0</u>	<u>4,960</u>
a. total square feet	b. square feet within 100 ft.	c. square feet between 100 ft. and 200 ft.

5. Has an alternatives analysis been done and is it attached to this NOI? Yes No

6. Was the lot where the activity is proposed created prior to August 1, 1996? Yes No
3 lots prior to 1996

3. Coastal Resource Areas: (See 310 CMR 10.25-10.35)

Note: for coastal riverfront areas, please complete **Section B.2.f.** above.

B. Buffer Zone & Resource Area Impacts (temporary & permanent) (cont'd)

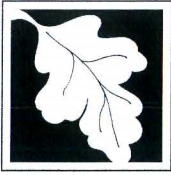

Massachusetts Department of Environmental Protection
 Bureau of Resource Protection - Wetlands

Provided by MassDEP:

WPA Form 3 – Notice of Intent

Massachusetts Wetlands Protection Act M.G.L. c. 131, §40
 & Northborough Wetlands Protection Bylaw & Regulations

 MassDEP File Number

 Document Transaction Number

Northborough

 City/Town

Check all that apply below. Attach narrative and supporting documentation describing how the project will meet all performance standards for each of the resource areas altered, including standards requiring consideration of alternative project design or location.

Online Users:
 Include your document transaction number (provided on your receipt page) with all supplementary information you submit to the Department.

<u>Resource Area</u>	<u>Size of Proposed Alteration</u>	<u>Proposed Replacement (if any)</u>
a. <input type="checkbox"/> Designated Port Areas	Indicate size under Land Under the Ocean, below	
b. <input type="checkbox"/> Land Under the Ocean	_____	
	1. square feet	

	2. cubic yards dredged	
c. <input type="checkbox"/> Barrier Beach	Indicate size under Coastal Beaches and/or Coastal Dunes below	
d. <input type="checkbox"/> Coastal Beaches	_____	_____
	1. square feet	2. cubic yards beach nourishment
e. <input type="checkbox"/> Coastal Dunes	_____	_____
	1. square feet	2. cubic yards dune nourishment
	<u>Size of Proposed Alteration</u>	<u>Proposed Replacement (if any)</u>
f. <input type="checkbox"/> Coastal Banks	_____	
	1. linear feet	
g. <input type="checkbox"/> Rocky Intertidal Shores	_____	
	1. square feet	
h. <input type="checkbox"/> Salt Marshes	_____	_____
	1. square feet	2. sq ft restoration, rehab., creation
i. <input type="checkbox"/> Land Under Salt Ponds	_____	
	1. square feet	

	2. cubic yards dredged	
j. <input type="checkbox"/> Land Containing Shellfish	_____	
	1. square feet	
k. <input type="checkbox"/> Fish Runs	Indicate size under Coastal Banks, inland Bank, Land Under the Ocean, and/or inland Land Under Waterbodies and Waterways, above	

	1. cubic yards dredged	
l. <input type="checkbox"/> Land Subject to Coastal Storm Flowage	_____	
	1. square feet	
4. <input type="checkbox"/> Restoration/Enhancement	If the project is for the purpose of restoring or enhancing a wetland resource area in addition to the square footage that has been entered in Section B.2.b or B.3.h above, please enter the additional amount here.	
	_____	_____
	a. square feet of BVW	b. square feet of Salt Marsh
5. <input type="checkbox"/> Project Involves Stream Crossings		
	_____	_____
	a. number of new stream crossings	b. number of replacement stream crossings

C. Other Applicable Standards and Requirements

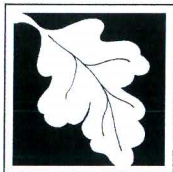

WPA Form 3 – Notice of Intent

Massachusetts Wetlands Protection Act M.G.L. c. 131, §40
& Northborough Wetlands Protection Bylaw & Regulations

MassDEP File Number _____

Document Transaction Number _____

Northborough _____

City/Town _____

- This is a proposal for an Ecological Restoration Limited Project. Skip Section C and complete Appendix A: Ecological Restoration Notice of Intent – Required Actions (310 CMR 10.11).

Streamlined Massachusetts Endangered Species Act/Wetlands Protection Act Review

1. Is any portion of the proposed project located in **Estimated Habitat of Rare Wildlife** as indicated on the most recent Estimated Habitat Map of State-Listed Rare Wetland Wildlife published by the Natural Heritage and Endangered Species Program (NHESP)? To view habitat maps, see the *Massachusetts Natural Heritage Atlas* or go to http://maps.massgis.state.ma.us/PRI_EST_HAB/viewer.htm.

- a. Yes No

If yes, include proof of mailing or hand delivery of NOI to:

Natural Heritage and Endangered Species Program
 Division of Fisheries and Wildlife
 1 Rabbit Hill Road
 Westborough, MA 01581

2017 _____

b. Date of map

If yes, the project is also subject to Massachusetts Endangered Species Act (MESA) review (321 CMR 10.18). To qualify for a streamlined, 30-day, MESA/Wetlands Protection Act review, please complete Section C.1.c, and include requested materials with this Notice of Intent (NOI); OR complete Section C.1.f, if applicable. *If MESA supplemental information is not included with the NOI, by completing Section 1 of this form, the NHESP will require a separate MESA filing which may take up to 90 days to review (unless noted exceptions in Section 2 apply, see below).*

- c. Submit Supplemental Information for Endangered Species Review*

1. Percentage/acreage of property to be altered:

(a) within wetland Resource Area _____

percentage/acreage

(b) outside Resource Area _____

percentage/acreage

2. Assessor's Map or right-of-way plan of site

2. Project plans for entire project site, including wetland resource areas and areas outside of wetlands jurisdiction, showing existing and proposed conditions, existing and proposed tree/vegetation clearing line, and clearly demarcated limits of work **

(a) Project description (including description of impacts outside of wetland resource area & buffer zone)

(b) Photographs representative of the site

C. Other Applicable Standards and Requirements (cont'd)

* Some projects **not** in Estimated Habitat may be located in Priority Habitat, and require NHESP review (see <http://www.mass.gov/eea/agencies/dfg/dfw/natural-heritage/regulatory-review/>). Priority Habitat includes habitat for state-listed plants and strictly upland species not protected by the Wetlands Protection Act.

** MESA projects may not be segmented (321 CMR 10.16). The applicant must disclose full development plans even if such plans are not required as part of the Notice of Intent process.

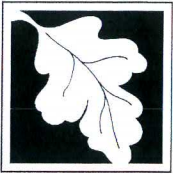

WPA Form 3 – Notice of Intent

Massachusetts Wetlands Protection Act M.G.L. c. 131, §40
& Northborough Wetlands Protection Bylaw & Regulations

MassDEP File Number

Document Transaction Number

Northborough

City/Town

- (c) MESA filing fee (fee information available at http://www.mass.gov/dfwele/dfw/nhesp/regulatory_review/ mesa/ mesa_fee_schedule.htm). Make check payable to "Commonwealth of Massachusetts - NHESP" and **mail to NHESP** at above address

Projects altering 10 or more acres of land, also submit:

- (d) Vegetation cover type map of site
- (e) Project plans showing Priority & Estimated Habitat boundaries
- (f) OR Check One of the Following

- 1. Project is exempt from MESA review. Attach applicant letter indicating which MESA exemption applies. (See 321 CMR 10.14, http://www.mass.gov/dfwele/dfw/nhesp/regulatory_review/ mesa/ mesa_exemptions.htm; the NOI must still be sent to NHESP if the project is within estimated habitat pursuant to 310 CMR 10.37 and 10.59.)
- 2. Separate MESA review ongoing. a. NHESP Tracking # _____ b. Date submitted to NHESP _____
- 3. Separate MESA review completed. Include copy of NHESP "no Take" determination or valid Conservation & Management Permit with approved plan.

- 3. For coastal projects only, is any portion of the proposed project located below the mean high water line or in a fish run?
 - a. Not applicable – project is in inland resource area only
 - b. Yes No

If yes, include proof of mailing, hand delivery, or electronic delivery of NOI to either:

South Shore - Cohasset to Rhode Island border, and the Cape & Islands:

Division of Marine Fisheries -
 Southeast Marine Fisheries Station
 Attn: Environmental Reviewer
 1213 Purchase Street – 3rd Floor
 New Bedford, MA 02740-6694
 Email: DMF.EnvReview-South@state.ma.us

North Shore - Hull to New Hampshire border:

Division of Marine Fisheries -
 North Shore Office
 Attn: Environmental Reviewer
 30 Emerson Avenue
 Gloucester, MA 01930
 Email: DMF.EnvReview-North@state.ma.us

Also if yes, the project may require a Chapter 91 license. For coastal towns in the Northeast Region, please contact MassDEP's Boston Office. For coastal towns in the Southeast Region, please contact MassDEP's Southeast Regional Office.

C. Other Applicable Standards and Requirements (cont'd)

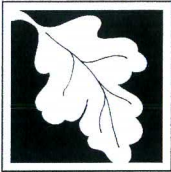

WPA Form 3 – Notice of Intent

Massachusetts Wetlands Protection Act M.G.L. c. 131, §40 & Northborough Wetlands Protection Bylaw & Regulations

Online Users:
Include your document transaction number (provided on your receipt page) with all supplementary information you submit to the Department.

4. Is any portion of the proposed project within an Area of Critical Environmental Concern (ACEC)?
- a. Yes No If yes, provide name of ACEC (see instructions to WPA Form 3 or MassDEP Website for ACEC locations). **Note:** electronic filers click on Website.
- b. ACEC
5. Is any portion of the proposed project within an area designated as an Outstanding Resource Water (ORW) as designated in the Massachusetts Surface Water Quality Standards, 314 CMR 4.00?
- a. Yes No
6. Is any portion of the site subject to a Wetlands Restriction Order under the Inland Wetlands Restriction Act (M.G.L. c. 131, § 40A) or the Coastal Wetlands Restriction Act (M.G.L. c. 130, § 105)?
- a. Yes No
7. Is this project subject to provisions of the MassDEP Stormwater Management Standards?
- a. Yes. Attach a copy of the Stormwater Report as required by the Stormwater Management Standards per 310 CMR 10.05(6)(k)-(q) and check if:
1. Applying for Low Impact Development (LID) site design credits (as described in Stormwater Management Handbook Vol. 2, Chapter 3)
 2. A portion of the site constitutes redevelopment
 3. Proprietary BMPs are included in the Stormwater Management System.
- b. No. Check why the project is exempt:
1. Single-family house
 2. Emergency road repair
 3. Small Residential Subdivision (less than or equal to 4 single-family houses or less than or equal to 4 units in multi-family housing project) with no discharge to Critical Areas.

D. Additional Information

- This is a proposal for an Ecological Restoration Limited Project. Skip Section D and complete Appendix A: Ecological Restoration Notice of Intent – Minimum Required Documents (310 CMR 10.12).

Applicants must include the following with this Notice of Intent (NOI). See instructions for details.

Online Users: Attach the document transaction number (provided on your receipt page) for any of the following information you submit to the Department.

1. USGS or other map of the area (along with a narrative description, if necessary) containing sufficient information for the Conservation Commission and the Department to locate the site. (Electronic filers may omit this item.)
2. Plans identifying the location of proposed activities (including activities proposed to serve as a Bordering Vegetated Wetland [BVW] replication area or other mitigating measure) relative to the boundaries of each affected resource area.

D. Additional Information (cont'd)

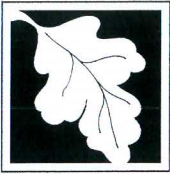

WPA Form 3 – Notice of Intent

Massachusetts Wetlands Protection Act M.G.L. c. 131, §40
& Northborough Wetlands Protection Bylaw & Regulations

MassDEP File Number

Document Transaction Number

Northborough

City/Town

- 3. Identify the method for BVW and other resource area boundary delineations (MassDEP BVW Field Data Form(s), Determination of Applicability, Order of Resource Area Delineation, etc.), and attach documentation of the methodology.
- 4. List the titles and dates for all plans and other materials submitted with this NOI.

Proposed Site Plan of 0 Hudson Street, Northborough, MA (3 sheets)

a. Plan Title

Connorstone Engineering

Vito Colonna

b. Prepared By

c. Signed and Stamped by

12/24/2020

1"=20'

d. Final Revision Date

e. Scale

f. Additional Plan or Document Title

g. Date

- 5. If there is more than one property owner, please attach a list of these property owners not listed on this form.
- 6. Attach proof of mailing for Natural Heritage and Endangered Species Program, if needed.
- 7. Attach proof of mailing for Massachusetts Division of Marine Fisheries, if needed.
- 8. Attach NOI Wetland Fee Transmittal Form
- 9. Attach Stormwater Report, if needed.

E. Fees

- 1. Fee Exempt: No filing fee shall be assessed for projects of any city, town, county, or district of the Commonwealth, federally recognized Indian tribe housing authority, municipal housing authority, or the Massachusetts Bay Transportation Authority.

Applicants must submit the following information (in addition to pages 1 and 2 of the NOI Wetland Fee Transmittal Form) to confirm fee payment:

255

11/24/2020

2. Municipal Check Number

3. Check date

256

11/24/2020

4. State Check Number

5. Check date

Circle Assets LLC

6. Payor name on check: First Name

7. Payor name on check: Last Name

F. Signatures and Submittal Requirements



WPA Form 3 – Notice of Intent

Massachusetts Wetlands Protection Act M.G.L. c. 131, §40
& Northborough Wetlands Protection Bylaw & Regulations

MassDEP File Number

Document Transaction Number

Northborough

City/Town

F. Signatures and Submittal Requirements

I hereby certify under the penalties of perjury that the foregoing Notice of Intent and accompanying plans, documents, and supporting data are true and complete to the best of my knowledge. I understand that the Conservation Commission will place notification of this Notice in a local newspaper at the expense of the applicant in accordance with the wetlands regulations, 310 CMR 10.05(5)(a).

I further certify under penalties of perjury that all abutters were notified of this application, pursuant to the requirements of M.G.L. c. 131, § 40. Notice must be made by Certificate of Mailing or in writing by hand delivery or certified mail (return receipt requested) to all abutters within 100 feet of the property line of the project location.

1. Signature of Applicant (Scott Goddard)

10/29/2020
2. Date

3. Signature of Property Owner (if different)

4. Date

5. Signature of Representative (Norse Environmental Services, LLC.)

1-28-21
6. Date

For Conservation Commission:

Two copies of the completed Notice of Intent (Form 3), including supporting plans and documents, two copies of the NOI Wetland Fee Transmittal Form, and the city/town fee payment, to the Conservation Commission by certified mail or hand delivery.

For MassDEP:

One copy of the completed Notice of Intent (Form 3), including supporting plans and documents, one copy of the NOI Wetland Fee Transmittal Form, and a copy of the state fee payment to the MassDEP Regional Office (see Instructions) by certified mail or hand delivery.

Other:

If the applicant has checked the "yes" box in any part of Section C, Item 3, above, refer to that section and the Instructions for additional submittal requirements.

The original and copies must be sent simultaneously. Failure by the applicant to send copies in a timely manner may result in dismissal of the Notice of Intent.

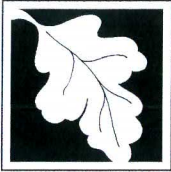

Massachusetts Department of Environmental Protection
 Bureau of Resource Protection - Wetlands
NOI Wetland Fee Transmittal Form
 Massachusetts Wetlands Protection Act M.G.L. c. 131, §40

Important: When filling out forms on the computer, use only the tab key to move your cursor - do not use the return key.



A. Applicant Information

1. Location of Project:

0 Hudson Street	Northborough
a. Street Address	b. City/Town
256	\$1,300
c. Check number	d. Fee amount

2. Applicant Mailing Address:

Scott	Goddard	
a. First Name	b. Last Name	
Circle Assets LLC	c. Organization	
291 Main Street, Suite 8		
d. Mailing Address		
Northborough	MA	01532
e. City/Town	f. State	g. Zip Code
508-393-3784	scott@goddardconsultingllc.com	
h. Phone Number	i. Fax Number	j. Email Address

3. Property Owner (if different):

_____	_____	
a. First Name	b. Last Name	

c. Organization		

d. Mailing Address		
_____	_____	_____
e. City/Town	f. State	g. Zip Code
_____	_____	_____
h. Phone Number	i. Fax Number	j. Email Address

B. Fees

Fee should be calculated using the following process & worksheet. **Please see Instructions before filling out worksheet.**

Step 1/Type of Activity: Describe each type of activity that will occur in wetland resource area and buffer zone.

Step 2/Number of Activities: Identify the number of each type of activity.

Step 3/Individual Activity Fee: Identify each activity fee from the six project categories listed in the instructions.

Step 4/Subtotal Activity Fee: Multiply the number of activities (identified in Step 2) times the fee per category (identified in Step 3) to reach a subtotal fee amount. Note: If any of these activities are in a Riverfront Area in addition to another Resource Area or the Buffer Zone, the fee per activity should be multiplied by 1.5 and then added to the subtotal amount.

Step 5/Total Project Fee: Determine the total project fee by adding the subtotal amounts from Step 4.

Step 6/Fee Payments: To calculate the state share of the fee, divide the total fee in half and subtract \$12.50. To calculate the city/town share of the fee, divide the total fee in half and add \$12.50.

To calculate filing fees, refer to the category fee list and examples in the instructions for filling out WPA Form 3 (Notice of Intent).

CIRCLE ASSETS LLC
291 MAIN ST
STE 8
NORTHBOROUGH, MA 01532

256
63-7052/2113

11/24 2020

CHECKSAFE

PAY TO THE ORDER OF Commonwealth of MA \$ 1300.00

One thousand three hundred dollar even DOLLARS

AVIDIA BANK

FOR NOI fee - Hudson St

[Signature]

Security features are indicated. Check on back.

CIRCLE ASSETS LLC
291 MAIN ST
STE 8
NORTHBOROUGH, MA 01532

255
63-7052/2113

11/24 2020

CHECKSAFE

PAY TO THE ORDER OF Town of Northboro \$ 1525.00

One thousand five hundred twenty five even DOLLARS

AVIDIA BANK

FOR NOI fee - Hudson St

[Signature]

Security features are indicated. Check on back.

Notification to Abutters Under the
Massachusetts Wetlands Protection Act
And the Northborough Wetlands Bylaw

In accordance with the second paragraph of Massachusetts General Laws
Chapter 131, Section 40, you are hereby notified of the following:

- A. The name of the applicant is Circle Assets LLC.
- B. The applicant has filed a Notice of Intent with the Conservation Commission of the Town of Northborough seeking permission to remove, fill, dredge or alter an area subject to protection under the wetland protection act (General Laws Chapter 131, Section 40).
- C. The address where the activity is proposed is 0 Hudson Street Map 53 Lots 19-21.
- D. The activity consists of construction of two duplex buildings with associated appurtenances and a constructed wetland replication area and BLSF compensatory storage.
- E. Copies of the filing may be examined at the Conservation Commission Office, Town Hall, between the hours of 8 am and 4 PM, Monday through Friday **pending COVID restriction guidelines**. Please call prior to coming: 508-393-5015.

A digital PDF of the application can be requested by email:
conservation@town.northborough.ma.us

- F. Copies of the Notice of Intent/Request for Determination may be viewed from:
Norse Environmental Services, Inc. 92 Middlesex Road, Unit 4 Tyngsboro, MA.
- G. Information regarding the date, time and place of the public hearing may be obtained from the Conservation Commission Office by calling 508-393-5015 during the hours listed above.

NOTE: Notice of the public hearing, including its date, time, and place, will be published at least five (5) days in advance in The Worcester Telegram and Gazette.

NOTE: Notice of the public hearing, including its date, time and place will be posted in the Town Hall not less than forty-eight (48) hours in advance. All meetings take place remotely via Zoom until the end of the COVID state of emergency.

NOTE: You also may contact The Northborough Conservation Commission or the Department of Environmental Protection (DEP) Regional Office for more information about this application or the Wetlands Protection Act. To contact DEP call the Central Region Office at 508-792-7650.



Town of Northborough Office of the Board of Assessors

63 Main Street, Massachusetts 01532-1994
Mon, Wed, Thurs 8-4 / Tuesday 8-7 / Friday 7-12
508-393-5005 phone, 508-393-6996 fax

Certified Abutters List Request Please allow 10 business days.

DATE OF REQUEST	10/28/2020
REQUESTING COMPANY	Connorstone Engineering
CONTACT PERSON	Vito Collona
PHONE	1 (508) 410-8574
EMAIL	
PROPERTY ADDRESS(es)	0 Hudson Street (3 lots, no buildings)
MAP/PARCEL(s)	Map: 53, Lots: 19, 20, 21
OWNER(s)	Circle Assets
OWNER MAILING ADDRESS(es)	291 Main Street, Suite 8, Northboro

REQUESTING BOARD	APPLICABLE REGULATIONS	ABUTTERS / DISTANCE	#LABEL SETS	FEE
<input type="checkbox"/> Planning Board – Scenic Road	Town Code Chapter 2-52-050	Owners within 100' of property	3 sets	\$15
<input type="checkbox"/> Planning Board – Site Plan	Planning Board Rules & Regulations Section 7.2 D(5)	Owners within 300' of property	3 sets	\$15
<input type="checkbox"/> Planning Board – Special Permit	MGL Chapter 40A Section 11	Owners within 300' of property	3 sets	\$15
<input type="checkbox"/> Planning Board – Subdivisions	MGL Chapter 41 Section 81T	Owners within 300' of property	3 sets	\$15
<input type="checkbox"/> ZBA – Zoning Board of Appeals	MGL Chapter 40A Section 11	Owners within 300' of property	3 sets	\$15
<input checked="" type="checkbox"/> Conservation Commission	MGL Chapter 131, Section 40, MA Wetlands Protection Act, & the Northborough Wetlands Protection Bylaw	100' of property, unless otherwise stated	1 set	\$10
<input type="checkbox"/> Board of Health	Dependent on project	Owners within 100' of property	3 sets	\$15
<input type="checkbox"/> Board of Selectman: Fuel Storage	MGL Chapter 148, Section 13	Abutting owners & directly opposite	3 sets	\$15
<input type="checkbox"/> Board of Selectman: Liquor License	MGL Chapter 138, Section 15A	Abutting owners, & any school, church, or hospital within 500' of property	2 sets	\$25
<input type="checkbox"/> Board of Selectman: Pole Petition	MGL Chapter 166, Section 22	Abutting owners & directly opposite	1 set	\$15
<input type="checkbox"/> Board of Selectmen: Street Acceptance	Dependent on project	Abutting owners & directly opposite	1 set	\$10
<input type="checkbox"/> DPW – Dept of Public Works	Northborough Town Bylaws: Part 2 - General Legislation,	Owners with driveways on the street	?	\$10+
<input type="checkbox"/> Engineering: Earth Works	Chapter 2-28, Earth Removal	Dependent on project: _____ feet	1 set	\$10
<input type="checkbox"/> Other: _____		Owners within 100' of property		

To the Requesting Board/s: We certify that, from our Real Estate Property Lists, the following persons attached hereto appear as owners of all abutting property, as specified by the appropriate regulation (including, but not limited to, owners of land directly opposite said proposed activity on any public or private street or way, or across a body of water), as amended to the best of our knowledge and belief. If the property is within abutting distance of another Town, please contact their Assessors Office for another abutters list.

DATE OF CERTIFICATION 10-28-2020

Julie Brownlee/Megan Hennessy for the Board of Assessors
jbrownlee@town-northborough.ma.us ; mhennessy@town-northborough.ma.us

3 parcels on Hudson St - Maps 53-19 + 53-20 + 53-21

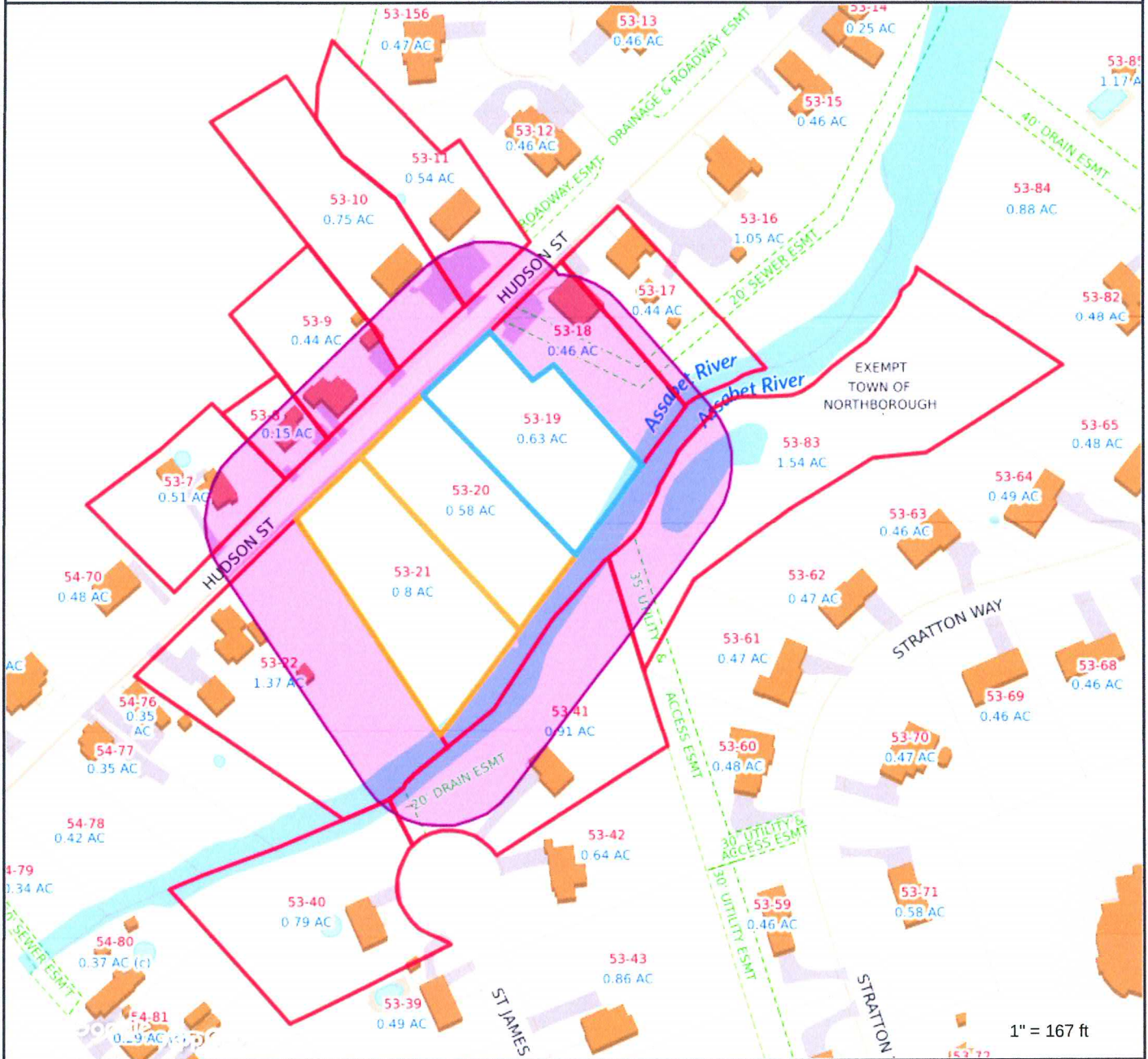

Property Information

Property ID 053.0-0019-0000.0
 Location 0 HUDSON STREET
 Owner CIRCLE ASSETS LLC



**MAP FOR REFERENCE ONLY
 NOT A LEGAL DOCUMENT**

Town of Northborough, MA makes no claims and no warranties, expressed or implied, concerning the validity or accuracy of the GIS data presented on this map.

3 Hudson Street parcels: Maps 53/19, 53/20, 53/21

October 28, 2020

ID	Address#	Street Name	Owner Name	Owner Name 2	Owner Address 1	Owner Address 2	Owner City	Owner State	Owner Zip
053.0-0019-0000.0	0	HUDSON STREET	CIRCLE ASSETS LLC		291 MAIN STREET Suite 8		NORTHBOROUGH	MA	01532
053.0-0020-0000.0	0	HUDSON STREET	CIRCLE ASSETS LLC		291 MAIN STREET Suite 8		NORTHBOROUGH	MA	01532
053.0-0021-0000.0	0	HUDSON STREET	CIRCLE ASSETS LLC		291 MAIN STREET Suite 8		NORTHBOROUGH	MA	01532
053.0-0022-0000.0	84	HUDSON STREET	LYDEN ROBERT JAMES AND	LYDEN CYNTHIA D	84 HUDSON STREET		NORTHBOROUGH	MA	01532
053.0-0007-0000.0	87	HUDSON STREET	KCB DEVELOPMENT LLC		353 OLD BAY ROAD		BOLTON	MA	01740
053.0-0008-0000.0	91	HUDSON STREET	GAM REAL ESTATE INVESTMENTS LLC		56 HUDSON STREET		NORTHBOROUGH	MA	01532
053.0-0009-0000.0	93	HUDSON STREET	MULONE STEVEN J	PETERSON OLIVIA	93 HUDSON STREET		NORTHBOROUGH	MA	01532
053.0-0010-0000.0	101-103	HUDSON STREET	ASSABET REALTY TRUST		469 RIVER ROAD		HUDSON	MA	01749
053.0-0011-0000.0	105-107	HUDSON STREET	ASSABET REALTY TRUST		469 RIVER ROAD		HUDSON	MA	01749
053.0-0018-0000.0	106	HUDSON STREET	DIMANNO DEBORAH K TRUSTEE	106 HUDSON STREET REALTY TRUST	64 MAPLE STREET		NORTHBOROUGH	MA	01532
053.0-0017-0000.0	110	HUDSON STREET	SVRK REALTY LLC		21 SOUTHWEST CUTOFF		NORTHBOROUGH	MA	01532
053.0-0040-0000.0	37	ST JAMES DRIVE	VALERY CRAIG M	SALGADINHO ERICA A	37 ST JAMES DRIVE		NORTHBOROUGH	MA	01532
053.0-0041-0000.0	38	ST JAMES DRIVE	WHITING MICHAEL G		38 ST JAMES DRIVE		NORTHBOROUGH	MA	01532
053.0-0083-0000.0	0	STRATTON WAY	TOWN OF NORTHBOROUGH	CONSERVATION COMMISSION	63 MAIN STREET		NORTHBOROUGH	MA	01532

AFFIDAVIT OF SERVICE

Under the Massachusetts Wetlands Protection Act
& Northborough Wetlands Protection Bylaw & Regulations

I, Steve Eriksen hereby certify under the pains and penalties of perjury that on 2/1/2021 I gave notification to abutters in Compliance with the second paragraph of Massachusetts General Law Chapter 131, Section 40, and the DEP Guide to Abutter Notification dating April, 8, 1994 in connection with the following matter:

A Notice of Intent was filed under the Massachusetts Wetlands Protection Act and Northborough Wetlands Protection Bylaw with the Northborough Conservation Commission on 2/1/2021 for three adjacent parcels of land: Map 53, Lot 19, 20, 21, at 0 Hudson Street in Northborough, MA.

The form of the notification, and the list of abutters to whom it was given, and their addresses, are attached to this Affidavit of Service.



(Name)

2-1-21

(Date)



NORSE ENVIRONMENTAL SERVICES, INC.

92 Middlesex Road, Unit 4

Tyngsboro, MA 01879

TEL. (978) 649-9932 • FAX (978) 649-7582

Website: www.norseenvironmental.com

January 26, 2021

Northborough Conservation Commission
Northborough Town Hall
63 Main Street
Northborough, MA 01532

RE: Regulatory Discussion
0 Hudson Street, Northborough, MA

Dear Northborough Conservation Commission:

Norse Environmental Services, Inc. is pleased to submit this Regulatory Discussion on behalf of the applicant, Circle Assets, LLC for the proposed project at 0 Hudson Street, Northborough, MA (Assessors Map: 53, Lots: 19, 20, 21).

1.0 Existing Conditions

The site of the proposed project is located on Hudson Street, between house numbers 84 and 106. The site consists of two lots, Lot 1 (adjacent to house number 84) and Lot 2 (adjacent to house number 106), totaling 2.19 acres. These lots were created from redividing three lots that had been created prior to 1996.

Overall, the site is largely undeveloped. A gravel parking area, in the northern corner of Lot 1, is a result of abutter encroachment, and has been present for several decades. In addition, a town sewer line runs through the north-west corner of Lot 1.

The site contains Bordering Vegetated Wetlands (BVW), Bordering Land Subject to Flooding (BLSF), Bank, and Riverfront Area (RA). Historically, the site consisted of fields, with a ditch running west to east diagonally across the entire site. This ditch is still present within the BVW, beginning on Lot 2 and draining to the southeast of Lot 1 where it borders the Assabet River. From Hudson Street, a 12” – diameter concrete masonry pipe discharges onto Lot 2 and has caused erosion that transports sediment towards the BVW. The BVW Buffer Zone (the Buffer Zone) to the north of the BVW is dominated by invasive Japanese knotweed (*Fallopia japonica*). Japanese knotweed dominates from the BVW boundary up to the road shoulder and gravel parking area (**Photos 1-4**), including significant portions of the inner and outer Riverfront Area. **Table 1** provides the square footage of Riverfront Area on each lot and the square footage of disturbed area within the Riverfront Area. **Table 2** provides specific area calculations for the existing conditions, the proposed conditions, and the proposed net change of area.

Table 1: Total Riverfront Area and Disturbed Areas within Riverfront Area

	Lot 1	Lot 2	Total
Riverfront Area on Site	35,470 SF	37,118 SF	72,588 SF
Disturbed or Altered Area within Riverfront Area on Site	2,860 SF	0 SF	2,860 SF

Table 2: Total Site Comparison

	Existing		Proposed		Net Change	
	Lot 1	Lot 2	Lot 1	Lot 2	Lot 1	Lot 2
Land Under Water Bodies	4,283	4,351	4,283	4,351	-	-
BVW	11,902	10,793	11,902	11,073	-	280
Natural Buffer	3,712	31,452	20,564	30,976	16,852	(476)
Invasive Species	19,101	5,024	-	-	(19,101)	(5,024)
Developed area (gravel, building, lawn, driveway)	2,860	-	5,109	5,220	2,249	5,220
Total Area (Jurisdictional)	41,858	51,620	41,858	51,620	-	-
	-	-	-	-	-	-
Outside Jurisdiction (Developed)	1,032	-	1,032	-	-	-

*Red is net decrease of area.



Photo 1: Japanese knotweed dominates the Buffer Zone and Riverfront Area (inner and outer) beyond the gravel parking area on Lot 1 (8/18/19).



Photo 2: BVW flag A15, looking west along the wetland line. Note the Japanese knotweed to the right of the photo, between the BVW and Hudson Street (8/18/19).



Photo 3: BVW flag A15, looking east along the wetland line. BVW is seen on the right side of the photo and Japanese knotweed to the left, dominating the landscape between the BVW and the edge of the site (8/18/19).



Photo 4: Japanese knotweed dominates the edge of the site along Hudson Street (8/18/19).

2.0 Site History

In March of 2010 a Superseding Order of Conditions (SOC), DEP File #247-0953 was issued by the MassDEP Central Regional Office (CERO) for the construction of a duplex home which involved 1,930 square feet (SF) of BVW filling, 4,751 SF of BLSF impacts and 6,730 SF of RA impacts. In December of 2010 an Order of Conditions (OOC) was issued by the Northborough Conservation Commission under the Northborough Wetlands Protection Bylaw for the same project with the same impacts.

3.0 Proposed Project

Lot 1:

The applicant is proposing a duplex home on Lot 1. This duplex will be constructed within the outer Riverfront Area and Buffer Zone. The structure will be built on the footprint of the degraded gravel parking area and within the vegetated patch of Japanese knotweed. The proposed duplex will result in 4,735 SF of permanent alteration to Lot 1. Riverfront Area restoration is proposed for 16,560 SF of Lot 1. At the moment, Lot 1 has Japanese knotweed growing from the edge of the gravel area to the edge of the BVW. Natural Riverfront Area will be restored by removing the Japanese knotweed through an invasive species management plan (see attached report). See **Table 3** for figures on the existing and proposed Riverfront Area.

Additionally, the proposed grading will provide compensatory storage for all BLSF alteration (see site plans for cut/fill calculations). See **Table 4** for figures on existing and proposed BLSF.

Lot 2:

The applicant is proposing an additional duplex home on Lot 2. This duplex will be constructed outside of Riverfront Area with the exception of a small portion of retaining wall and a wetland replication area. The duplex will require filling 520 SF of BVW to minimize impacts to the Riverfront Area. This impact will be mitigated with the creation of an 800 SF wetland replication area (within the outer Riverfront Area). An alternatives analysis has been attached to show that other locations for a similar unit would be within the outer riparian zone, which is an alternative allowable under 10.58(4).

Although the proposal results in minor BVW impacts, the net impact to cumulative resource areas is greatly reduced by the proposed location. The BVW impact amounts to 520 SF, while a larger replication area of 800 SF is proposed. On Lot 2, the proposed duplex will result in 110 SF of permanent alteration to Riverfront Area, yet Riverfront Area restoration is proposed for 1,700 SF. Natural Riverfront Area will be restored by removing Japanese knotweed through an invasive species management plan (see attached). See **Table 3** for figures on the existing and proposed Riverfront Area details.

The grading proposed will provide compensatory storage for all BLSF alteration (see site plans for cut/fill calculations). The applicant also proposes to install rip-rap below the stormwater pipe that discharges onto the lot to stop erosion of soil, which is currently occurring during rainstorms. See **Table 4** for figures on existing and proposed BLSF.

Table 3: Riverfront Area Comparison

	Existing		Proposed		Net Change	
	Lot 1	Lot 2	Lot 1	Lot 2	Lot 1	Lot 2
Riverfront Area - Inner Riparian Zone	18,824	17,650	18,824	17,650	-	-
Natural Buffer	3,712	13,335	9,393	13,055	5,681	(280)
BVW	9,431	4,315	9,431	4,595	-	280
Invasive Species	5,681	-	-	-	(5,681)	-
Riverfront Area - Outer Riparian Zone	16,646	19,468	16,646	19,468	-	-
Natural Buffer	524	11,582	9,440	13,057	8,916	1,475
BVW	2,471	6,186	2,471	6,186	-	-
Invasive Species	10,791	1,700	-	-	(10,791)	(1,700)
Developed area (gravel, building, lawn, driveway)	2,860	-	4,735	225	1,875	225
Total Riverfront	35,470	37,118	35,470	37,118	-	-

*Red is net decrease of area.

Table 4: BLSF Comparison

	Existing		Proposed		Net Change	
	Lot 1	Lot 2	Lot 1	Lot 2	Lot 1	Lot 2
BLSF Total	16,563	31,684	16,533	30,202	(30)	(1,482)
Natural Buffer	565	28,149	16,533	30,202	15,968	2,053
Invasive Species	15,998	3,535	-	-	(15,998)	(3,535)

*Red is net decrease of area.

3.1 General Summary of the Overall Proposed Project:

The project proposes two duplex buildings in the outer Riverfront Area, impacts to the BVW and BLSF, and mitigation in the form of BVW replication and BLSF compensatory storage elsewhere on site. The project proposes to exterminate Japanese knotweed from the property and restore the BVW Buffer Zone to a natural meadow space. Work is proposed within the inner riparian zone for compensatory flood storage mitigation and the removal of invasive species. The project will result in a 100% natural Riverfront Area, extending 135 linear feet from the river bank to the proposed duplexes. At the moment, only 20 linear feet of natural Riverfront Area exists.

4.0 Regulatory Compliance for Proposed Impacts to Resource Areas:

This redevelopment project falls under the jurisdiction of the Wetlands Protection Act (the WPA) and the Northborough Wetlands Protection Bylaw (the Bylaw) and is subject to their respective regulations. Under the WPA, the project must comply with the performance standards set forth in 310 CMR 10.57 for Bordering Vegetated Wetlands (BVW), 310 CMR 10.57 for Bordering Land Subject to Flooding (BLSF) and 310 CMR 10.58 for Riverfront Area. Under the Bylaw, the project must comply with sections 4.1.1 for Wetland Replication, 4.2.3 for 15' No Disturb & 30' No structure Buffer Zones to BVW, and 4.3.3 for Riverfront Area. The following discussion will describe the proposed impacts to resource areas and how the proposed project will comply with the aforementioned regulations.

4.1 BVW Impacts and Regulatory Compliance

The project proposes a small wetland impact (520 SF) to minimize greater disturbance in the Buffer Zone and Riverfront area on the site. 520 SF of degraded BVW will be impacted to construct the duplex on Lot 2. This BVW will be replicated within an invasive dominated buffer zone, directly adjacent to the wetland impact area. The proposed project will also restore a natural buffer zone around the replication area. The goal will be to produce and enlarge a higher quality BVW from what will be altered. Refer to the *Alternative Site Plan of 0 Hudson Street* which demonstrates a regulatory compliance plan that avoids BVW. This plan would require significant inner Riverfront Area impacts. There is less overall impact to resource areas by proposing the development closer to Hudson Street than it is to propose the development deeper into the Riverfront Area.

Compliance Under the WPA

The impacts to BVW are subject to the performance standards set forth in 310 CMR 10.55(4)(b). The following discussion will describe the projects compliance with each aspect of this regulation.

310 CMR 10.55(4)(b):

“Notwithstanding the provisions of 310 CMR 10.55(4)(a), the issuing authority may issue an Order of Conditions permitting work which results in the loss of up to 5000 square feet of Bordering Vegetated Wetland when said area is replaced in accordance with the following general conditions and any additional, specific conditions the issuing authority deems necessary to ensure that the replacement area will function in a manner similar to the area that will be lost:

The proposed wetland impact will allow for a significantly smaller project that is restricted from greater expansion and encroachment within the Buffer Zone and Riverfront.

- 1. The surface of the replacement area to be created (“the replacement area”) shall be equal to that of the area that will be lost (“the lost area”);*

This project proposes 1.5:1 wetland replication. 520 square feet of BVW fill and 800 square feet of replicated BVW is proposed.

Tthe ground water and surface elevation of the replacement area shall be approximately equal to that of the lost area;

The proposed wetland replication is directly adjacent to the area that is lost and will be graded to the same elevation (elev. 249)

- 2. The overall horizontal configuration and location of the replacement area with respect to the bank shall be similar to that of the lost area;*

The proposed wetland replication is directly adjacent to the area that is lost and will maintain same overall horizontal configuration.

- 3. The replacement area shall have an unrestricted hydraulic connection to the same water body or waterway associated with the lost area;*

The proposed wetland replication is along existing BVW of the wetland system and will maintain an unrestricted hydraulic connection.

- 4. The replacement area shall be located within the same general area of the waterbody or reach of the waterway as the lost area;*

The proposed wetland replication is in the same reach of the wetlands of the lost area.

5. *At least 75% of the surface of the replacement area shall be reestablished with indigenous wetland plant species within two growing seasons, and prior to said vegetative reestablishment any exposed soil in the replacement area shall be temporarily stabilized to prevent erosion in accordance with standard U.S. Soil Conservation Service methods; and*

The proposed wetland replication area will be monitored for two years to monitor the percent coverage of the vegetation. See the *Wetland Replication, Compensatory Storage, and Invasive Species Management Plans*, dated 1/26/21, for more details.

6. *The replacement area shall be provided in a manner which is consistent with all other General Performance Standards for each resource area in Part III of 310 CMR 10.00. In the exercise of this discretion, the issuing authority shall consider the magnitude of the alteration, and the significance of the project site to the interests identified in M.G.L. c. 131, Sec. 40, the extent to which adverse impacts are minimized, and the extent to which mitigation measures, including replication or restoration, area provided to contribute to the protection of the interests identified in M.G.L. c. 131, Sec. 40.*

The proposed wetland replication area has been chosen to meet the General Performance Standards. See the *Wetland Replication, Compensatory Storage, and Invasive Species Management Plans*, dated 1/26//19, for more details.

Compliance Under the Bylaw

The impacts to BVW are subject to the regulations and performance standards set forth in section 4.1 & 4.1.1 of the Bylaw. The following discussion will describe the projects compliance with each aspect of these regulations.

4.1 Activities within Areas Subject to Protection under the Wetlands Bylaw:

The general performance standards for Banks, Land Under Water Bodies, Bordering Land Subject to Flooding, Isolated Land Subject to Flooding and Riverfront Area shall be as stated in 310 CMR 10.00 as amended. The general performance standards for Bordering Vegetated Wetland (BVW) shall be as stated in 310 CMR 10.55 as amended except where an alteration of BVW is proposed. The Commission will consider projects requiring the permanent alteration of up to three thousand five hundred (3,500) square feet of BVW as permitted by 310 CMR 10.55(4)(b) as amended only if the applicant demonstrates:

- 1) *no practical alternative is available;*

No alternative is practicable to reduce net resource impacts as shown in the alternative analysis section of this report (see **5.0 Alternative Analysis**). The proposed BVW impact equates to 520 SF, which is less than 3,500 SF.

2) project scope and design minimize the amount of resource area destroyed;

The project scope has been reduced to minimize impacts to the net resource areas on the property.

3) in the judgment of the Commission such work will not lead to degradation of additional BVW; and

The project has been designed to prevent further expansion of development activities on the site by surrounding the homes with retaining walls.

4) replication area is provided in a ratio of 1.5:1 for the BVW destroyed.

The proposed replication area slightly exceeds a ratio of 1.5:1 for the BVW destroyed.

4.1.1 Performance Standards for Wetland Replication:

Where a replication of BVW is proposed, the applicant shall submit complete replication plans and a replication report with the Application for Permit. In addition, the following requirements shall apply:

a. The replication plan and report shall include, at a minimum, topography, location and size of BVW to be altered, the location and size of the replication area, a description of the BVW to be altered, and a description and detailed methodology of the replication work;

The proposed replication plan discusses existing BVW to be impacted.

b. The replication area shall be completed before the project is completed;

The proposed replication plan discusses the timeframe for the replication area being constructed in the same season as the wetland impact occurs.

c. A wetlands specialist with at least two years experience in wetlands replication shall supervise the replication work;

The proposed replication plan requires a wetland scientist with 2 years experience in wetland replication work.

d. Written reports shall be submitted by the applicant at the end of each growing season stating the condition of erosion controls and documenting the condition of growth of the replicated area;

The proposed replication plan requires a wetland scientist to prepare a report at the end of each growing season.

e. An as built report and an as built plan of the replication area, both certified by the wetlands specialist, shall be submitted and shall provide the date the BVW was excavated, the soil depth data of such BVW, the dates of planting and, if applicable, replanting of replication areas along with the percentage of cover of individual species; and

The proposed replication plan requires an as-built plan to be reviewed by the monitoring wetland scientist and an engineer or surveyor.

f. No certificate of compliance shall be issued for the Permit authorizing the replication work until all conditions of this section have been complied with and at least two full growing seasons have elapsed since the replication work began. At its discretion, the Commission may issue a certificate of compliance prior to the completion of two (2) full growing seasons upon receipt of a bond or other security in an amount and upon such terms as are acceptable to the Commission.

The applicant is aware that a COC is required once 2-years of monitoring work has been successfully completed.

4.2 Bordering Land Subject to Flooding Impacts and Regulatory Compliance

The proposed project will impact Bordering Land Subject to Flooding (BLSF) to allow for the construction of the duplexes on Lots 1 and 2. The total impact to BLSF is 21,470 SF. The project proposes grading that will provide full compensatory storage within the flood plain to replicate existing floodplain. See the site plans for cut and fill calculations. A total increase of 1,579 cubic feet of BLSF storage will be added.

Compliance Under the WPA

The impacts to BLSF are subject to the performance standards set forth in 310 CMR 10.57(4)(a). The following discussion will describe the projects compliance with each aspect of this regulation.

310 CMR 10.57(4)(a) - General Performance Standards for Bordering Land Subject to Flooding:

1. Compensatory storages shall be provided for all flood storage volume that will be lost as the result of a proposed project within Bordering Land Subject to Flooding, when in the judgment of the issuing authority said loss will cause an increase or will contribute incrementally to an increase in the horizontal extent and level of flood waters during peak flows.

Compensatory storage shall mean a volume not previously used for flood storage and shall be incrementally equal to the theoretical volume of flood water at each elevation, up to and including the 100-year flood elevation, which would be displaced by the proposed project. Such compensatory volume shall have an unrestricted hydraulic connection to the same waterway or water body. Further, with respect to waterways,

such compensatory volume shall be provided within the same reach of the river, stream or creek.

The proposed project proposes to provide full compensatory storage for all flood storage volume lost from re-grading at each increment horizontal within BLSF. The project grading proposes an increase of 1,579 cubic feet of flood storage over current conditions. This is a benefit to flooding on the Assabet River. On sheet 2 of 3 in the site plans, a BLSF & Compensatory Flood Storage Calculations table shows that for each elevation increment, the project results in an increase in flood plain storage volume.

2. Work within Bordering Land Subject to Flooding, including that work required to provide the above-specified compensatory storage, shall not restrict flows so as to cause an increase in flood stage or velocity.

The proposed cut grading is in directly adjacent areas as the proposed fill, with no restrictions to flood waters flooding the areas of compensatory storage.

3. Work in those portions of bordering land subject to flooding found to be significant to the protection of wildlife habitat shall not impair its capacity to provide important wildlife habitat functions. Except for work which would adversely affect vernal pool habitat, a project or projects on a single lot, for which Notice(s) of Intent is filed on or after November 1, 1987, that (cumulatively) alter(s) up to 10% or 5,000 square feet (whichever is less) of land in this resource area found to be significant to the protection of wildlife habitat, shall not be deemed to impair its capacity to provide important wildlife habitat functions. Additional alterations beyond the above threshold, or altering vernal pool habitat, may be permitted if they will have no adverse effects on wildlife habitat, as determined by procedures contained in 310 CMR 10.60.

The proposed project will disturb 21,470 SF of BLSF, of which 16,560 SF is dense Japanese Knotweed. This results in only 4,910 SF of 100% non-invasive BLSF impact. The other areas of BLSF have several invasive honeysuckle shrubs. A detailed wildlife habitat evaluation under 310 CMR 10.60 was conducted by a qualified wildlife biologist. See attached wildlife habitat evaluation. An Appendix B Wildlife Evaluation was completed, and no significant wildlife habitat or features were found, mainly due to the proposed BLSF and BVW impact areas consisting mainly of invasive species and sparse vegetation. No mapped rare wildlife habitat is mapped on the property.

4.3 Riverfront Area Impacts and Regulatory Compliance

The proposed project will impact Riverfront Area in the outer riparian zone for the construction of two duplexes. Mitigation for BVW and BLSF impacts will be performed within the inner and outer riparian zone. Invasive species removal will occur in the inner and outer riparian zone to increase and enhance the natural riverfront area present on the property.

The following table (5) outlines the existing conditions of the Riverfront Area on site. This includes degraded gravel areas and also areas of extensive invasive species degradation.

Table 5: Existing Conditions within Riverfront

	Existing	
	Lot 1	Lot 2
Riverfront Area - Inner Riparian Zone	18,824	17,650
Natural Buffer	3,712	13,335
BVW	9,431	4,315
Invasive Species	5,681	-
Riverfront Area - Outer Riparian Zone	16,646	19,468
Natural Buffer	524	11,582
BVW	2,471	6,186
Invasive Species	10,791	1,700
Developed area (gravel, building, lawn, driveway)	2,860	-
Total Riverfront	35,470	37,118

Compliance Under the WPA

The impacts to Riverfront Area are subject to the performance standards set forth in 310 CMR 10.58. The following discussion will describe the alternative analysis for the project and the projects compliance with 310 CMR 10.58.

Alternative Analysis

The proposed project has considered other alternative locations for the proposed duplexes. The proposed construction of two duplex units and restoring the Riverfront Area to natural conditions will increase wildlife habitat opportunity and enhance the natural resource areas on the property. The proposed project is the best alternative, providing more benefits than potentially constructing 3 single family homes on each of the 3 lots that had existed prior to 1996, or proposing the duplex for Lot 2 within the inner riparian zone of the Riverfront Area in an attempt to avoid minor BVW impact. Below, these alternatives will be described in detail to demonstrate how the proposed project is indeed the best alternative in terms of overall impact to resource areas, especially Riverfront Area.

Alternative 1: 3 Single Family Homes

This alternative would propose the development of the 3 original lots (pre-1996) as single-family homes with 5,000 SF of disturbance within riverfront for each lot. This would result in 15,000 SF of permanent riverfront disturbance. In addition, this alternative would require a filing as a limited project due to a lack of area to compensate for flood storage filling or would require the house to be placed on pilings. This alternative was therefore abandoned as a similar economic value could be achieved with only developing two lots as currently proposed.

Alternative 2: Previously Approved Project

This alternative would construct the previously approved project under Mass DEP #247-0953 and would result in the taking of one buildable lot and result in 1,930 SF of wetland impacts and 4,751 SF of degraded surfaces for a single duplex. 2,200 SF of riverfront area would also be impacted. When comparing the previously approved project to the currently proposed project, the proposed project results in significantly more natural Riverfront Area and cumulatively protects more resource area than the previously approved plan. This is a net benefit to the BVW, BLSF and Riverfront Area. **Table 6** and **Table 7** compare the previously approved project to the current proposed project. This alternative proposal did not consider all of the additional lots for development, nor did it include any riverfront restoration work to remove invasive species. As this alternative results in more wetland impacts, this alternative was abandoned.

Table 6: Riverfront Area Comparison with 2010 Project

	Existing	Proposed		Net Change
	Lot 1	Lot 1	2010 Project	
Riverfront Area - Inner Riparian Zone	18,824	18,824	18,824	-
Natural Buffer	3,712	9,393	3,712	5,681
BVW	9,431	9,431	9,431	-
Invasive Species	5,681	-	5,681	(5,681)
Riverfront Area - Outer Riparian Zone	16,646	16,646	16,646	-
Natural Buffer	524	9,440	3,712	5,728
BVW	2,471	2,471	2,471	-
Invasive Species	10,791	-	5,712	(5,712)
Developed area (gravel, building, lawn, driveway)	2,860	4,735	4,751	(16)
Total Riverfront	35,470	35,470	35,470	-

*Red is net decrease of area.

Table 7: BLSF Comparison with 2010 Project

	Existing	Proposed		Net Change
	Lot 1	Lot 1	2010 Project	
BLSF Total	16,563	16,533	16,563	(30)
Natural Buffer	565	16,533	5,170	11,363
Invasive Species	15,998	-	11,393	(11,393)

*Red is net decrease of area.

Alternative 3: 2 Duplex Units, Lot 2 duplex all in riverfront

This alternative would construct two duplex units but place the Lot 2 duplex in the middle of the lot. This would require 4,000 SF of Riverfront disturbance for Lot 2 alone. See **Figure 1**. This alternative was therefore abandoned. This alternative would avoid BVW alterations and would maintain work out of the inner riparian zone. This alternative would likely satisfy Riverfront Area standards but was not selected in order to preserve Riverfront Area.

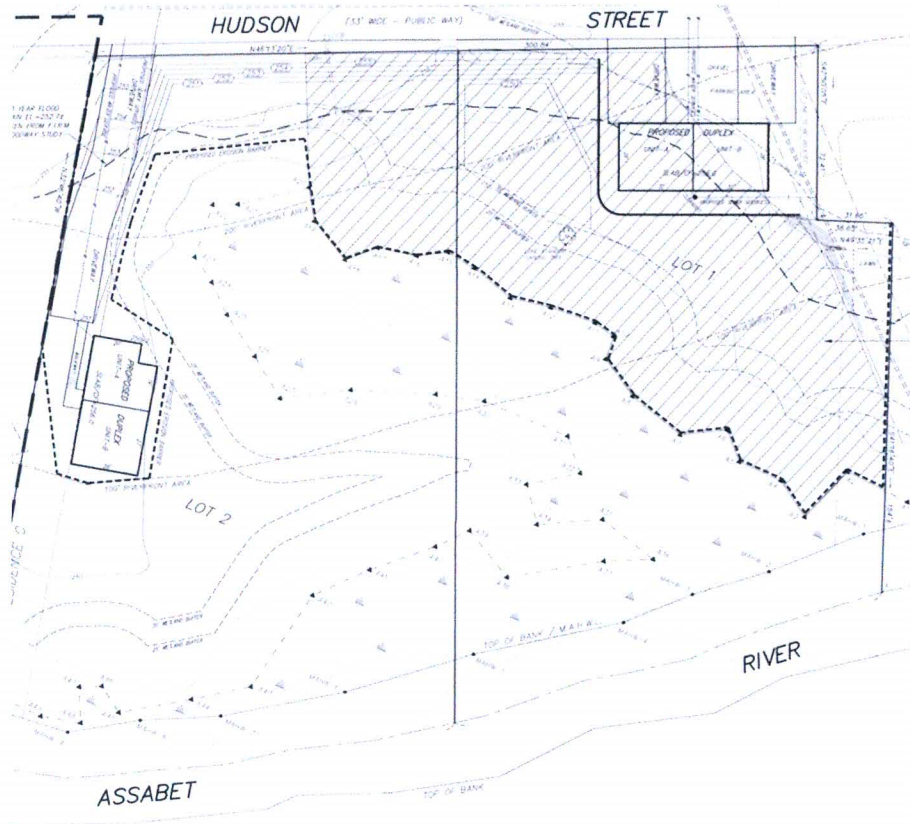

Figure 1: Alternative 2-duplex site plan

Alternative 4: 2 Duplex Units, Lot 2 duplex outside riverfront (Current proposed project)

This alternative would construct two duplex units but place the Lot 2 duplex outside the riverfront area. This alternative minimizes impacts to riverfront area, provides for significant riverfront and BLSF restoration and allows for reasonable economic value for the 3 lots that have existed prior to 1996. **Table 8** outlines the proposed conditions by area.

Table 8: Riverfront Area – Proposed Conditions

	Existing		Proposed		Net Change	
	Lot 1	Lot 2	Lot 1	Lot 2	Lot 1	Lot 2
Riverfront Area - Inner Riparian Zone	18,824	17,650	18,824	17,650	-	-
Natural Buffer	3,712	13,335	9,393	13,055	5,681	(280)
BVW	9,431	4,315	9,431	4,595	-	280
Invasive Species	5,681	-	-	-	(5,681)	-
Riverfront Area - Outer Riparian Zone	16,646	19,468	16,646	19,468	-	-
Natural Buffer	524	11,582	9,440	13,057	8,916	1,475
BVW	2,471	6,186	2,471	6,186	-	-
Invasive Species	10,791	1,700	-	-	(10,791)	(1,700)
Developed area (gravel, building, lawn, driveway)	2,860	-	4,735	225	1,875	225
Total Riverfront	35,470	37,118	35,470	37,118	-	-

*Red is net decrease of area.

As the site is previously developed it is to be reviewed under the redevelopment standards 310 CMR 10.58(5).

(5) Redevelopment Within Previously Developed Riverfront Areas; Restoration and Mitigation. Notwithstanding the provisions of 310 CMR 10.58(4)(c) and (d), the issuing authority may allow work to redevelop a previously developed riverfront area, provided the proposed work improves existing conditions. Redevelopment means replacement, rehabilitation or expansion of existing structures, improvement of existing roads, or reuse of degraded or previously developed areas. A previously developed riverfront area contains areas degraded prior to August 7, 1996 by impervious surfaces from existing structures or pavement, absence of topsoil, junkyards, or abandoned dumping grounds. Work to redevelop previously developed riverfront areas shall conform to the following criteria:

(a) At a minimum, proposed work shall result in an improvement over existing conditions of the capacity of the riverfront area to protect the interests identified in M.G.L. c. 131 § 40. When a lot is previously developed but no portion of the riverfront area is degraded, the requirements of 310 CMR 10.58(4) shall be met.

The proposed project increases natural riverfront area and depth by restoring a degraded area with 100% invasive species with natural riverfront meadow space. This includes restoration within the inner riparian zone.

(b) Stormwater management is provided according to standards established by the Department.

The project is for two duplex units which do not require stormwater management under the Departments standards.

(c) Within 200 foot riverfront areas, proposed work shall not be located closer to the river than existing conditions or 100 feet, whichever is less, or not closer than existing conditions within 25 foot riverfront areas, except in accordance with 310 CMR 10.58(5)(f) or (g).

No work within 100 feet of the river is proposed except for restoration and mitigation work for invasive species and compensatory storage. Restoration work will result in an increase from 20 feet to 135 feet of natural riverfront depth on the property.

(d) Proposed work, including expansion of existing structures, shall be located outside the riverfront area or toward the riverfront area boundary and away from the river, except in accordance with 310 CMR 10.58(5)(f) or (g).

The project has placed structures as far from the river as possible as allowable under zoning setbacks.

(e) The area of proposed work shall not exceed the amount of degraded area, provided that the proposed work may alter up to 10% if the degraded area is less than 10% of the riverfront area, except in accordance with 310 CMR 10.58(5)(f) or (g).

The project proposes work under 310 CMR 10.58(5)(f) and (g).

(f) When an applicant proposes restoration on-site of degraded riverfront area, alteration may be allowed notwithstanding the criteria of 310 CMR 10.58(5)(c), (d), and (e) at a ratio in square feet of at least 1:1 of restored area to area of alteration not conforming to the criteria. Areas immediately along the river shall be selected for restoration. Alteration not conforming to the criteria shall begin at the riverfront area boundary. Restoration shall include:

- 1. removal of all debris, but retaining any trees or other mature vegetation;*
- 2. grading to a topography which reduces runoff and increases infiltration;*
- 3. coverage by topsoil at a depth consistent with natural conditions at the site; and*
- 4. seeding and planting with an erosion control seed mixture, followed by plantings of herbaceous and woody species appropriate to the site;*

The project is using existing degraded areas on Lot 1 (2,860 SF). Additional restoration within invasive species would fall under 310 CMR 10.58(5)(f)(2), but this work is presented under 310 CMR 10.58(5)(g) to show that mitigation far exceeds standards.

(g) When an applicant proposes mitigation either on-site or in the riverfront areas within the same general area of the river basin, alteration may be allowed notwithstanding the criteria of 310 CMR 10.58(5)(c), (d), or (e) at a ratio in square feet of at least 2:1 of mitigation area to area of alteration not conforming to the criteria or an equivalent level of environmental protection where square footage is not a relevant measure. Alteration not conforming to the criteria shall begin at the riverfront area boundary.

The project proposes to restore 10,791 SF (Lot 1) and 1,700 SF (Lot 2) of invasive species area within the Riverfront to natural riverfront.

Compliance Under the Bylaw

The proposed impacts to Riverfront Area are subject to section 4.3.3 *Riverfront Area General Performance Standards* of the Northborough Wetlands Protection Bylaw Regulations.

4.3.3 General Performance Standards. No foundation, building, road, sidewalk, or other permanent structure shall be placed within the resource area except as allowed by 310 CMR 10.58. Furthermore, no grading, filling, excavation, removal of vegetation, or other construction activity shall be allowed within 200 feet of the annual mean high water level of any river. Notwithstanding the above, the Commission may allow work within the resource area provided the applicant demonstrates that the work will not be detrimental to the resource area. Furthermore the presumption of wetland resource alteration from fertilizers, pesticides, and de-icing chemicals may be overcome by providing qualified technical data to the Commission indicating that the chemical products will not alter the resource area or adjacent waters.

As shown above, the project meets the work permitted under 310 CMR 10.58. The proposed work has reduced impacts to the maximum extent possible and has also sought to provide extensive mitigation to restore riverfront with the net result of more natural riverfront than existing conditions.

4.4 Impacts to the 25' No Disturb & 35' No Structure Buffer Zones to BVW and Regulatory Compliance Under the Bylaw

The proposed project will impact the 25' No Disturb & 35' No structure Buffer Zones to BVW for the construction of a duplex building on Lot 2. Mitigation for BVW and BLSF impacts will be performed within these Buffer Zones. Invasive species removal will occur in these Buffer Zones to enhance the resource areas.

No foundation, building, road, sidewalk, or other permanent structure shall be placed within thirty five (35) feet of any resource area. Furthermore, no grading, filling, excavation, removal of vegetation or other construction activity shall be allowed within twenty five (25) feet of said resource areas. Notwithstanding the above, the Commission may allow work closer to resource areas if needed: (a) to provide access to an area where an alteration of resource areas has been allowed; (b) if the work qualifies as a

limited project (310 CMR 10.53 (3) as amended); or (c) for storm water outlet structures. In other projects the Commission may allow work closer to a resource area if the applicant demonstrates:

(1) alternatives have been considered and in the judgment of the Commission no practical alternative is available;

As shown above, the alternatives would require the loss of a buildable lot or result in more Buffer Zone, BLSF and Riverfront impacts. The proposed impacts have been reduced to the maximum extent practicable for the net resource area. The proposed work and structures will result in a permanent demarcation of activities on the lots and allow for the preservation of the remaining areas on the property.

(2) project scope and design minimize work in close proximity to resource areas;

As shown above, the alternatives would require either the loss of a buildable lot or more Buffer Zone and Riverfront Area impacts. The proposed impacts have been reduced to the maximum extent practicable.

(3) site conditions (including but not limited to slope, soil type and hydrology) will allow prevention of wetland damage from such work; and

As shown above, the alternatives would require the loss of a buildable lot or more Buffer Zone and Riverfront Area impacts. The proposed impacts have been reduced to the maximum extent practicable. Wetland impacts have been minimized to the maximum extent practicable.

(4) such work will not lead to encroachment on the resource area after completion of the project. For projects involving steep slopes, highly erodible soils, extensive disturbed areas, or hydrologic conditions likely to promote significant erosion, the Commission may require a wider undisturbed buffer to ensure protection of wetland resource areas. Furthermore, the presumption of wetland resource alteration from fertilizers and pesticides may be overcome by providing qualified technical data to the Commission indicating that the chemical products will not alter wetland resource areas.

The proposed project has reduced work in the 25-foot No Disturb Buffer and 35-foot No Structure Buffer wherever possible. The project is the smallest net impact to Buffer Zone, BVW, Riverfront Area and BLSF of each aforementioned alternative.

Conclusion

The project has been designed to minimize resource area impacts and satisfy the regulations and performance standards of the WPA and Northborough Wetlands Protection Bylaw, while providing important mitigation within multiple resource areas. Existing conditions involve the extensive growth of invasive species within wetland resource areas. After the proposed construction and mitigation take place, the entire site will see an increase in BVW square footage, an increase in BLSF flood storage, an increase in natural buffer zone square footage,

improved stormwater management, 120 feet of natural undisturbed Riverfront Area, and the eradication of an extensive mass of invasive species. Altogether, this project will result in the expansion and substantial improvement of the wetland resource areas on site.

Please feel free to contact us if you have any questions.



Steve Eriksen
Norse Environmental Services, Inc

CC: CERO-DEP, Wetlands Division, 8 New Bond Street, Worcester, MA 01606
Circle Assets LLC, 291 Main Street, Suite 8, Northborough, MA 01532



NORSE ENVIRONMENTAL SERVICES, INC.

92 Middlesex Road, Unit 4

Tyngsboro, MA 01879

TEL. (978) 649-9932 • FAX (978) 649-7582

Website: www.norseenvironmental.com

January 26, 2021

Northborough Conservation Commission
Northborough Town Hall
63 Main Street
Northborough, MA 01532

Re: Waiver Request
0 Hudson Street, Northborough, MA

Dear Northborough Conservation Commission:

Norse Environmental Services, Inc is pleased to submit this Waiver Request on behalf of the applicant, Circle Assets, LLC, for the construction of a retaining wall within the 35' BVW no structure buffer zone and 25' BVW no disturb buffer zone at the property located at 0 Hudson Street (Assessors Map 53 Lot 19, 20, 21) in Northborough, MA. This is a filing under the Northborough Wetlands Protection Bylaw only.

1.0 Existing Conditions

The site of the proposed project consists of two lots, totaling 2.19 acres. These two lots were created from 3 lots which existed prior to 1996. The lots are largely undeveloped except for a gravel parking area at the northern corner of Lot 1, which has existed for several decades as a result of abutter encroachment. In addition, a town sewer line runs through the north west corner of Lot 1. The site historically was old fields with a ditch running west to east diagonally across the property. This ditch is still present within the A-series wetland. The A-series wetland begins on Lot 2 and drains to the southeast of Lot 1 where it borders on the Assabet River. A 12" concrete masonry pipe discharges on to Lot 2 from Hudson Street and has caused erosion that is transporting sediment towards the wetland. The site contains Bordering Vegetated Wetlands (BVW), Bordering Land Subject to Flooding (BLSF), Bank, and Riverfront Area (RA). The Buffer Zone north of the A-series wetland is dominated with nearly 100% Japanese Knotweed from the wetland edge to the road shoulder and gravel parking area.

2.0 Proposed Retaining Wall and Performance Standards under the Northborough Wetland Protection Bylaw

The applicant proposes to construct a retaining wall within the 35' no structure buffer zone and 25' no disturb buffer zone to the on-site BVW. The retaining wall will allow for minimizing net impacts to resource areas on site (reduction of impacts to Riverfront Area and BLSF). minimize grading disturbance, and provide a defined limit of development.

The Northborough Wetland Protection Bylaw, *Section 4.2.3 Activities Within the Buffer Zone-General Performance Standards* states the following:

No foundation, building, road, sidewalk, or other permanent structure shall be placed within thirty (35) feet of any resource area... Notwithstanding the above, the Commission may allow work closer to resource areas if needed:

(a) to provide access to an area where an alteration of BVW has been allowed;

This is not applicable to the proposed project.

(b) if the work qualifies as a limited project (310 CMR 10.53 (3) as amended); or

This is not applicable to the proposed project.

(c) for storm water outlet structures.

This is not applicable to the proposed project.

In other projects the Commission may allow work closer to a resource area if the applicant demonstrates:

(1) alternatives have been considered and in the judgment of the Commission no practical alternative is available;

The alternative to the retaining wall would involve larger permanent impacts to Riverfront Area and BLSF impacts by keeping development near Hudson Street and further from the river. The retaining wall is the most practical alternative to the project as it minimizes disturbance within the 35' buffer while serving the purpose of the project.

(2) project scope and design minimize work in close proximity to resource areas;

As stated above, the retaining wall design minimizes work and disturbance within the 35' buffer zone and eliminates need for additional disturbance within Riverfront Area and BLSF.

(3) site conditions (including but not limited to slope, soil type and hydrology) will allow prevention of wetland damage from such work; and

The retaining wall is being proposed to allow for building construction, which warrants slope stabilization through the retaining of soils or grading due to site topography and existing conditions. Grading would cause more disturbance in close proximity to the resource area. The retaining wall will allow for building construction, stabilize the slope and preventing slope failure, while further protecting the site resource areas. Sediment and erosion controls will be placed at the limit of work.

(4) such work will not lead to encroachment on the resource area after completion of the project.

Building the retaining wall will not lead to encroachment on the resource area during and after completion of the project. The retaining wall would limit construction and grading activities

within the buffer zone and move the limit of work further away from the resource area compared to the grading of the slope. The limit of work will be demarcated prior to the commencement of work and once completed, the retaining wall would serve as a permanent physical barrier between the project and the resource area.

3.0 Conclusions

According to Section 3.9 of the Northborough Wetland Protection Bylaw (***Waivers***) the Commission may, *in any particular case, where such action is in the public interest and not inconsistent with the intent and purpose of the Wetlands Bylaw, waive strict compliance with those portions of the Regulations which are not required by the Wetlands Bylaw.*

Norse Environmental Services, Inc believes that the project qualifies for a Waiver for the 35' no structure and 25' no disturb accordance with Section 3.9 of Northborough Wetland Protection Bylaw. The 35' no structure and 25' no disturb provisions of the Wetlands Bylaw is not required by the Bylaw given that certain provisions are met. As stated in the Section 4.2.3 of the local Wetland Protection Bylaw, *the Commission may allow work closer to a resource area if the applicant demonstrates compliance with Section 4.2.3(1) through (4).* As demonstrated above, the project meets the provisions under Section 4.2.3(1) through (4). As previously stated, the retaining wall will minimize disturbance within Riverfront Area and BLSF in accord with the intent and purpose of the Wetlands Bylaw. Furthermore, the retaining wall minimizes disturbance within the resource areas on site, helping protect the wetland resource areas which are in public interest. The applicant's proposal to remove 24,125 SF of invasive species and restore and enhance the BLSF by invasive species management is a significant improvement to the resource areas on site.

Please feel free to contact us if you have any questions.



Steve Eriksen
Norse Environmental Services, Inc



NORSE ENVIRONMENTAL SERVICES, INC.

92 Middlesex Road, Unit 4

Tyngsboro, MA 01879

TEL. (978) 649-9932 • FAX (978) 649-7582

Website: www.norseenvironmental.com

January 26, 2021

Wetland Replication, Compensatory Storage, and Invasive Species Management Plans

0 Hudson Street
(Map 53, Lots 19, 20, 21)
Northborough, MA

Submitted to:
Northborough Conservation Commission
Northborough Town Hall
63 Main Street
Northborough, MA 01532

Prepared for:
Circle Assets, LLC
291 Main Street, Suite 8
Northborough, MA 01532

Norse Environmental Services, Inc

1.0 Existing Conditions & Proposed Impacts

The property currently consists of vacant lots. A BVW system is located on site and is dominant in red maple, northern white oak, silky dogwood, sensitive fern, bittersweet and grape. The adjacent upland area is dominant in Japanese knotweed, bittersweet and northern white oak. The proposed project will result in approximately 520 sf of BVW alteration. The impact area is located between wetland flags A20-A23. Massachusetts Inland Wetland Replication Guidelines, March 1, 2002 states that wetland mitigation should involve reducing impacts to wetland resources through a three-step process:

1) Avoiding of BVW wetland impacts-

Due to lot size and wetland resources located on site, Buffer Zone of BVW impact is unavoidable; however, impacts to wetlands have been minimized to the greatest extent possible. Total avoidance was possible only with an extensively large amount of further impact to Riverfront Area.

2) Minimizing necessary impacts as much as possible-

The minimization of wetland impacts was performed by the reduction of each duplex size and location.

3) Replicating losses that cannot be avoided-

The project will impact approximately 520 square feet of BVW. Under this replication plan the project proposes a replication area of 800 square feet (1.5:1 ratio) as mitigation. The replication area is proposed directly adjacent to the impacted area. This replication plan was designed in accordance with the DEP "Massachusetts Wetland Replication Guidelines," dated March 2002.

2.0 Impact Area

The impact area is located between wetland flags A20-A23 in the northwest section of the parcel. The impact area is part of a scrub/shrub wetland system (see **Photo 1**). The wetland system is dominant in red maple, northern white oak, silky dogwood, sensitive fern, bittersweet and grape. Soils within the BVW consist of an O horizon of a 10YR2/1 at depth 1-12" with oxidized rhizospheres at 1" and a C horizon at a depth of 12-20" of a 10Y5/3 with mottles at 10YR5/6. Water was found at 12". Soils within the larger wetland and the impact area are classified by Natural Resource Conservation Service (NRCS) as Walpole Sandy Loam.



Photo 1: BVW impact area (2/12/19)

3.0 Function and Values of the Wetland and Proposed Wetland Replication Area

GROUNDWATER RECHARGE/DISCHARGE

The area seasonally holds surface water and acts as an area of storage and filtration of groundwater. The replication area will be hydrologically connected to existing BVW but at the same relative elevation and have similar topography.

FLOODFLOW ALTERATION

The BVW seasonally holds surface water and periodically retains flood water during precipitation events helping reduce potential for flood damage. The replication area will have similar topography and elevation as the adjacent BVW and an equal surface area available for water storage and flood damage prevention.

FISH AND SHELLFISH HABITAT

The BVW impact area and the adjacent BVW areas are part of a scrub shrub wetland system, and although the area seasonally floods, there is no open water which could serve as and sustain fish and shellfish habitat.

SEDIMENT/TOXICANT/PATHOGEN RETENTION

The area seasonally holds surface water and acts as an area of storage and filtration of groundwater. The seasonal ponding and slow-moving water allow suspended sediment particles to settle out of the water helping remove sediments, nutrients and pollutants. The replication area will have similar topography as the adjacent BVW and an equal surface area available for water storage, flood damage prevention, and sediment filtration. The selected vegetation will be similar to the existing cover within the existing BVW which will aid in nutrient and pollutant filtration.

NUTRIENT REMOVAL/RETENTION/TRANSFORMATION

The area seasonally holds surface water and acts as an area of storage and filtration of groundwater. The existing wetland plant community will continue to filter nutrients and retain surface and ground water. The replication area has been designed at a similar topography with similar vegetation in order to reproduce the nutrient removal and retention capacity of the existing BVW system on site.

PRODUCTION EXPORT (Nutrient)

The BVW onsite consists of a freshwater scrub shrub wetland with several shrubs that produce food (berries and seeds) for existing wildlife. These species of shrubs will remain in the un-impacted section of the wetland system. The wetland mitigation area will also be planted with these species so that the mitigated wetland areas will also provide this important wetland resource function.

SEDIMENT/SHORELINE STABILIZATION

The BVW seasonally holds surface water, ground water and flood water during storm events. Since the mitigation area will have twice the amount of surface area of the proposed impact area this additional area will aid in the prevention of flood damage and flood erosion on and off the site for both down-stream fresh water systems and water moving through these systems to the Cape Cod and Buzzards Bay shoreline.

WILDLIFE HABITAT

The site is not located within NHESP Priority Habitat. Existing wildlife habitat within the proposed Impact Area consists of: shelter, food, aestivation, hibernation and migratory opportunities. These habitat characteristics are provided by the presence of: fruiting shrubs, dense shrub thickets, a diverse herbaceous layer, rotting logs, and woody debris. These habitat features are common and present within both the adjacent wetland and upland areas on-site. These existing wetland habitat characteristics will remain in the un-impacted wetland area and will be replicated to the greatest extent practicable under this Replication Plan so that none of the current wildlife habitat features will be lost.

4.0 Proposed Replication Area

The proposed replication area will be located along wetland flags A15-A20 (see **Photo 2**). The replication area was selected due to its relative location and topography; which is similar to the adjacent wetland and wetland impact area. The replication area has Japanese Knotweed, bittersweet and northern white oaks. Soils consisted of 0-14" of 10YR2/2 silty loam and 14-20" of 10YR5/3 loam with 10YR5/6 mottles. Water was found at 16". The replacement area will have an unrestricted hydraulic connection to the same wetland system as the lost area. The replacement area connects to the same delineated BVW system as the lost area. The replication area will be created by excavating down to hydric soils and/or soils with strong redoximorphic features (i.e. mottles, presence of free water). The area will then be backfilled with organic soil from an outside source.



Photo 2: Proposed replication area (2/12/19)

4.1 Planting Selection

The vegetation selected for the replication area includes species that are native to the site and are also located within the adjacent wetland. Shrubs will be planted 8-10 feet on center unless the qualified wetland scientist in the field recommends otherwise. The vegetation selected for the restoration area includes species that are native to the site and are also located within the adjacent BVW. Precise placement of plants may be determined by the wetland scientist in the field prior to installation. All plants shall be distributed randomly throughout the area.

Trees:

- 2 Red Maples (*Acer rubrum*)(5-foot high)

Shrubs:

- 3 Sweet pepperbush (*Clethra alnifolia*)(one gal.pot)
- 3 Highbush blueberry (*Vaccinium corymbosum*)(one gal.pot)
- 7 Silky dogwood (*Cornus amomum*)(one gal.pot)

Ground Cover

- 15 Cinnamon fern (*Osmundastrum cinnamomeum*)
- 1lb, ERNST Seeds FACW Meadow Mix

4.2 General Installation Procedures

Supervision: A wetland scientist (with 2-years of experience in wetland replication construction) shall be on-site to monitor construction of the mitigation areas to ensure compliance with the mitigation plan and to make adjustments when appropriate to meet mitigation goals. The supervisor shall submit installation report to Northborough Conservation Commission as described below. Reports shall contain details of all work performed and photographs of completed conditions.

Timing: Replication construction should commence in the same season as the filling of the impacted wetland. The installation of plantings for replication area shall be accomplished during the growing season between April 16 and May 31 or between September 16 and October 30. Construction of the replication area can be accomplished outside the growing season if necessary, however stabilization measures may be required until the area is planted.

Step 1: Stake limits of work & install ECB. Stake out limits of all work for replication area. Erosion control barriers shall then be installed in the form of staked siltation fence and mulch sock (or similar invasive-free barrier) shall be placed at the limit of work for the replication area. **Erosion Controls removal deadline:** Temporary devices and structures to control erosion and sedimentation in and around mitigation sites will be kept in place until the replication area is stabilized, and shall be properly disposed of as soon as the site is stable. Sediment collected by these devices will be removed and placed upland in a manner that prevents its erosion and transport to a waterway or wetland.

Step 2: Remove trees and vegetation. Remove necessary vegetation for work and the construction of the replication area and access impact area.

Step 3: Excavation of replication Area. Prior to any soil excavation, a storage area for soil and leaf litter shall be prepared; soil shall not be stored in buffer zone. Topsoil, leaf litter, and subsoil shall be stockpiled separately. An excavator shall remove existing soils up to the edge of the staked replication area boundary, to a depth at which redoximorphic features become visible at the soil surface and/or 6-12 inches below proposed final grade.

Step 4: Excavation of impact area. An excavator shall remove existing organic soils up to the edge of the staked fill area boundary. Excavated organic soils from fill areas will be removed off-site due to invasive species seeds. Organic soil for the replication area will be supplied from an outside source. These supplemental soils will be uncontaminated and have an organic content of between 12-20%. A wetland scientist shall evaluate and confirm the cleanliness and organic content of the replication area soils.

Step 5: Final grading of replication area. Following excavation work, final grading and seeding should be completed as soon as possible to minimize erosion. Organic topsoil with an organic content of 12-20% shall be placed within the replication area to a depth even with the surrounding, existing wetland and in correlation with the proposed elevation on design plan.

Final elevation will be determined by the supervising wetland scientist while in the field during construction. Hummocks will be created atop final grade to mirror those of adjacent wetland.

Step 6: Add woody debris and rocks. Prior to planting, woody debris of various sizes and rocks shall be added to the replication area as to cover at least 4% of the ground throughout the mitigation area. These materials shall not include invasive species.

Step 7: Planting. The vegetation selected for the replication areas includes species that are native to the site. Precise citing of plants may be determined by the wetland scientist in the field prior to installation. All plants shall be distributed randomly throughout the area with shrubs spaced at 8'-10' on center, and herbaceous species 3' or less on center. Leaf litter shall be spread throughout area if available. All plants will have its roots thoroughly watered prior to backfilling with soil, and a soil saucer/berm constructed around trees and shrubs to retain water. Once all work is complete an erosion control barrier will be installed to enclose the replication area around trees and shrubs to retain water. Leaf litter shall be spread throughout area. Wetland seed mix consisting of ERNST FACW Meadow Mix or similar shall be scattered evenly by hand throughout the replication area.

Step 8: Replication Monitoring

a. **Seasonal monitoring reports** shall be prepared for the replication area by a qualified wetland scientist for a period of 2 additional years after installation. This monitoring program will consist of early summer and early fall inspections, and will include photographs and details about the vitality of the replication area. The replication area shall be monitored for invasive species during construction and during the post-construction monitoring period, by a qualified wetland scientist. If invasive species are observed, they will be addressed immediately through mechanical control methods involving hand-cutting and hand-removal of established species. Any removed species should be properly disposed of as well. Results of invasive species monitoring, and control measures will be reported as part of the yearly monitoring reports that will be required for the wetland mitigation areas. Monitoring reports shall be submitted to the Conservation Commission by December 30th of each year. Monitoring reports shall describe, using narratives, plans, and color photographs, the physical characteristics of the replication area with respect to stability, soil characteristics, survival of vegetation and plant mortality, aerial extent and distribution, species diversity and vertical stratification (i.e. herb, shrub and tree layers).

b. **At least 75% of the surface area** of the replication area shall be re-established with indigenous plant species within two growing seasons. If the replication area does not meet the 75% re-vegetation requirement by the end of the second growing season, after installation, the Applicant shall submit a remediation plan to the Conservation Commission for approval so that the replication area will achieve the 75% re-surfacing area goals.

Step 9: As-built Survey Upon meeting the criteria for 75% cover of indigenous species after two growing seasons, the replication areas will be surveyed for as-built conditions. The as-built

plan will be submitted to the Conservation Commission along with a request for a Certificate of Compliance.

5.0 Proposed Compensatory Storage

Pre-Construction meeting: Prior to the commencement of work, the site contractor shall meet with the supervising wetland scientist. Meeting shall explain how compensatory work shall be conducted to limit disturbance of natural woody vegetation.

Supervision: A wetland scientist shall monitor construction activities within the compensatory storage mitigation areas to ensure compliance with the mitigation plan and to make adjustments when appropriate to meet mitigation goals.

Step 1: Stake limits of work & install ECB. Stake out limits of all work for replication area. Erosion control barriers shall then be installed in the form of staked siltation fence and mulch sock (or similar invasive-free barrier) shall be placed at the limit of work for the replication area.

Erosion Controls Removal deadline. Temporary devices and structures to control erosion and sedimentation in and around mitigation sites will be kept in place until the replication area is stabilized, and shall be properly disposed of as soon as the site is stable. Sediment collected by these devices will be removed and placed upland in a manner that prevents its erosion and transport to a waterway or wetland.

Step 2: Excavate compensatory storage. Complete regrading required for compensatory storage. All graded areas should have 4” of top soil after grading is completed.

Step 3: Stabilize and seed compensatory storage. All areas of compensatory storage shall be seeded and then mulched with weed free straw. Ground surface shall result in a minimum of 90% ground cover. The seeding rate should follow manufacturers requirements. Seed mix shall be ERNST *PA New England Province Riparian Mix* or other seedmix approved by the Commission.

Step 4: As-built Survey.

Once grading is completed, the compensatory areas will be surveyed for as-built conditions. The as-built plan will be submitted to the Conservation Commission along with a request for a Certificate of Compliance.

6.0 Proposed Invasive Species Management Plan

6.1 Introduction

The purpose of this Invasive Species Management Plan (ISMP) is to restore natural riverfront and buffer zone from a nearly 100% invasive species cover to naturalized areas. This ISMP outlines the procedure for managing and the removal of invasive species within the Riverfront, Buffer Zone, and bordering vegetated wetlands (BVW) showed on the site plans (Map 53, Lot 19, 20, 21). Work will be performed in compliance with the Wetlands Protection Act and the Northborough Wetlands Protection Bylaws and Regulations.

6.2 Goals of the Invasive Species Management Plan

The primary goal of this ISMP is to eradicate, to the greatest extent practicable, the invasive plant species and in particular Japanese knotweed within the Management Area.

6.2.1 Location of the Planned Management Area

This ISMP specifies a portion of the area known as 0 Hudson Street, Northborough, MA (Map 53, Lot 19, 20, 21). This area is shown in **Figure 1** and also shown on the existing conditions plan in the NOI plans titled, *Existing Conditions Plan of 0 Hudson Street in Northborough, MA* (3 sheets), Connorstone Engineering, 12/24/2020

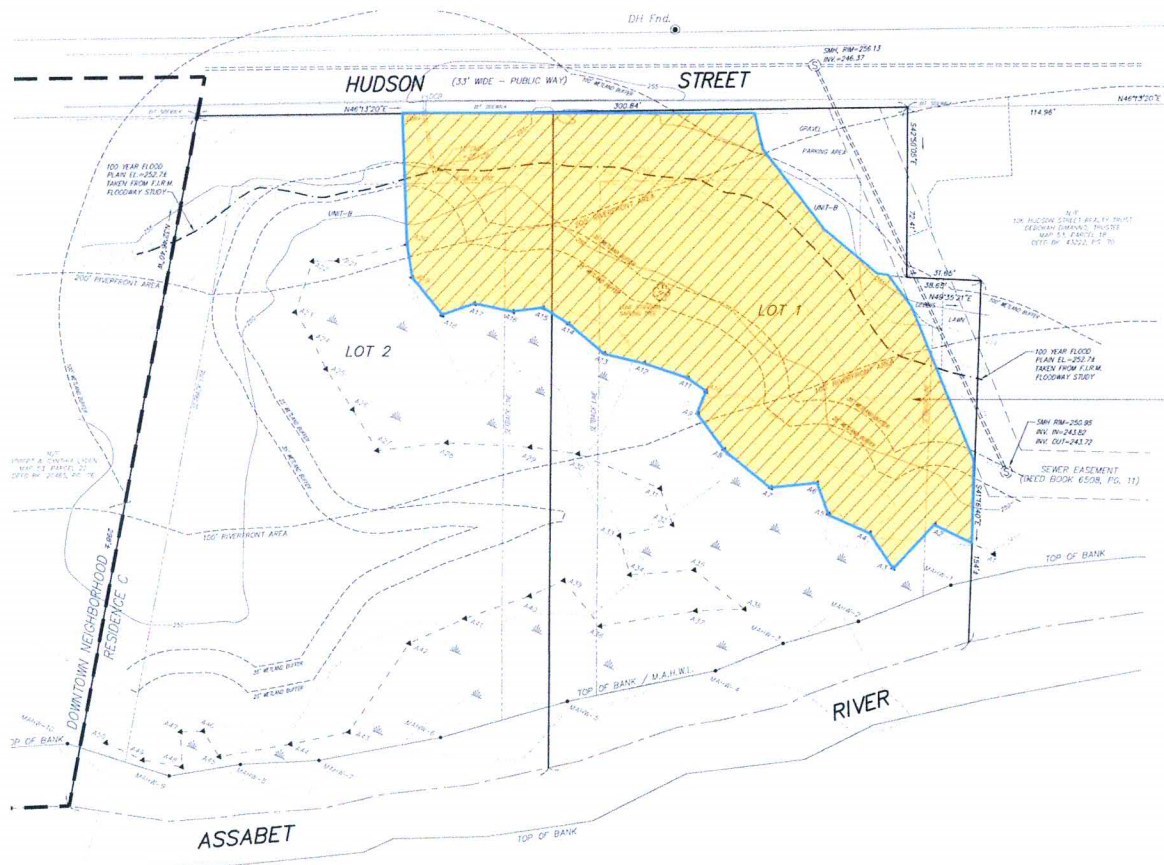

Figure 1: Invasive Species Management Zone (22,218 SF)

6.3 Protection Zones

The Riverfront and BVW is under the jurisdiction of both the MA WPA and the Northborough Wetlands Protection Bylaw. The site as shown on the existing conditions plan has a considerable amount of invasive plant species, particularly Japanese knotweed.

In order to protect the BVW, the following is recommended as regards to treatment within the Riverfront, Buffer Zone and edges of the BVW.

- a. Soils will be removed from the site to prevent future growth of invasive Japanese knotweed. This initial disturbance will significantly decrease the chances of regrowth and future eradication efforts. Soil amendments will be spread across the area to provide adequate growing mediums for upland plantings and seed mixes.
- b. Herbicide treatment will be limited to the regrowth of Japanese knotweed and woody invasive species that emerge after the initial soil removal and amendment effort.
- c. A licensed herbicide applicator chosen by the applicant and approved by the Northborough Conservation Commission shall perform all chemical treatments within the Riverfront Area and BVW.
- d. Chemical treatment should occur between early summer and late in the growing season but prior to plant senescence, or following the manufacturer's instructions regarding the species of plant and its responsiveness. Initial removal of vegetation and soils should occur before seed production.
- e. Foliar spray shall be used on new growth of Japanese Knotweed.
- f. A qualified professional should submit a brief annual report to the Northborough Conservation Commission during implementation of the ISMP. This report should document the results of management efforts, including methods, and temporal changes in the cover percentage of invasive plant species to ensure that the current methods are effective and to provide suggestions for adaptive management actions.

6.4 Methods of Invasive Species Management

Invasive species management will involve mechanical control methods and chemical control methods. The method chosen for a given vegetation management problem will attempt to achieve a long-term, low-maintenance invasive species management program through the encouragement of a stable native plant community. Vegetation management includes: invasive plant and top-soil removal, top-soil amendments, native species planting. Removal of trees isn't proposed.

The implementation of the ISMP by the owner shall commence upon the approval of the ISMP by the Northborough Conservation Commission and shall terminate on the two (2) year anniversary of said approval.

During the ISMP program, special care must be taken to prevent invasive species from expanding into the Riverfront, BVW and Buffer Zone area. Species such as:

1. Japanese knotweed (*Fallopia japonica*)

These species are already present on site and will be discouraged from expanding by mechanical and chemical methods listed above. Any proposed chemical management within the Riverfront or Buffer Zone must be performed per the regulations and following the manufacturer instructions.

The focus for the first two years will be the removal and prevention of re-sprouting of mature invasive species by removing the invasive vegetation and top-soil within the ISMP zone,

providing soil amendments, planting native species, and foliar spraying the regrowth of any invasive plant. The next four years of management will be focused on the continued removal and prevention through the encouragement of native plant growth and foliar spraying invasive sprouts with herbicide.

6.4.1 Specific Treatment Recommendations

- 1) Japanese knotweed (*Fallopia japonica*), other woody invasive species.
 - i) Remove invasive plants and top-soils within the ISMP zone. This will remove the root systems and seed bank of the Japanese knotweed.
 - ii) Removal from site only under Mass State laws to approved recycling sites.
 - iii) Amend the area with new top-soil, free of any invasive root systems or seeds.
 - iv) Plant native vegetation and seed mixes throughout the area.
 - v) Treat new growth with foliar herbicide spray.

6.5 ISMP Planting Plan

See **Table 1** for a list of the plants that will be installed in the ISMP area. The seed mix will be spread after the first treatment of the year. During the fall of the first year, shrubs will be planted.

Table 1: ISMP Planting Plan

Seed Mix			
ERNST Seeds FACW Meadow Mix or equivalent*	10 lbs (each application)		
Common Name	Scientific Name	Number	Size
Shrubs (n= 100)*			
Sweet Pepperbush (FAC+)	<i>Clethra alnifolia</i>	20	3 Gal. pot
Witch Hazel (FACU)	<i>Hamamelis virginiana</i>	20	3 Gal. pot
Alternate-leaved Dogwood (UPL)	<i>Cornus alternifolia</i>	20	3 Gal. pot
Silky Dogwood (FACW)	<i>Cornus amomum</i>	20	3 Gal. pot
Black Chokeberry (FAC)	<i>Aronia/Photinia melanocarpa</i>	20	3 Gal. pot

*Planting species and seed mixes may be substituted with Conservation Commission approval with similar native species with the same indicator status if certain species are unavailable.

6.7 ISMP management time

The management time frame will commence from the date the first invasive species removal work is completed. The annual monitoring report will review what was performed that year, what removal techniques were effective to reduce invasive plant species populations, and what removal techniques will be reused and which will be discarded for a more effective technique. The goal is that in 2 years, there will be a dominance of varied native plant species on site and the elimination of the invasive species that are currently within the Invasive Species Management Zone. The monitoring report will be sent to the Northborough Conservation Commission.

7.0 Conclusion

The project and proposed wetland impacts have been minimized to the greatest extent practicable. The mitigation measures that were described throughout this report were designed to improve the wetland resource areas throughout the site. The project design also satisfies all state and federal statutory interests and performance standards.

Please feel free to contact us if you have any questions.



Steve Eriksen
Norse Environmental Services, Inc



NORSE ENVIRONMENTAL SERVICES, INC.

92 Middlesex Road, Unit 4

Tyngsboro, MA 01879

TEL. (978) 649-9932 • FAX (978) 649-7582

Website: www.norseenvironmental.com

August 18, 2019

Northborough Conservation Commission
Northborough Town Hall
63 Main Street
Northborough, MA 01532

Re: Wetland Border Report
0 Hudson Street, Northborough, MA

Dear Northborough Conservation Commission:

On August 18, 2019, wetland resources were delineated on land located at the above referenced site. One Bordering Vegetated Wetland was delineated with foil tags/pink flags labeled with the series A1-A54. This wetland is dominant in sensitive fern, sedges, rushes, loosestrife, goldenrod, dogwood and red maple. The adjacent upland is dominant in goldenrod, Japanese knotweed, rose, black raspberry and upland grasses. Department of Environmental Protection BVW field data forms were documented at wetland flag # A11 (see attached forms).

The Mean Annual High Water of a mapped perennial stream was also delineated on site with flag series MAHW 1-11. The top of Bank of the river corresponded with the MAHW line. The river banks are 6-12 inches in height and are vegetated with ferns, dogwood, and sedges.

According to the Mass GIS data layers for NHESP, this site not is located within Estimated and/or Priority Habitat of Rare Wildlife, and no mapped potential or certified vernal pools are located on site. The site is not located in an ACEC; but is located in a jurisdictional FEMA Flood Zone which means the resource area Bordering Land Subject to Flooding is located from the wetland line up to the 100-year FEMA flood elevation.

Any work within the resource area (BVW or BLSF) and/or the 100-foot BVW buffer zone requires a Request for Determination (RDA) or Notice of Intent (NOI) be filed with the Conservation Commission. If you need further assistance with permitting, please call us we would be happy to assist.

Sincerely,

Steve Eriksen
Norse Environmental Services, Inc

DEP Bordering Vegetated Wetland (310 CMR 10.55) Delineation Field Data Form

Applicant: _____
 Check all that apply:

- Vegetation alone presumed adequate to delineate BVW boundary: fill out Section I only
- Vegetation and other indicators of hydrology used to delineate BVW boundary: fill out Sections I and II
- Method other than dominance test used (attach additional information)

Prepared by: Steve Eriksen

DEP File #: _____

Project location: 0 Hudson St, Northboro

Section I. Vegetation

Observation Plot Number: A-II Transect Number: Upgradient Date of Delineation: 18-Aug-19

Sample Layer and Plant Species	Scientific name	% Cover	% Dominance	Dominant Plant (yes or no)	Wetland Indicator Category*
<i>Tree Layer</i>					
<i>Sapling Layer</i>					
<i>Shrub Layer</i>					
Japanese-Knotweed	<i>Reynoutria japonica</i>	63%	75.9%	Yes	FACU
Allegheny blackberry	<i>Rubus allegheniensis</i>	20%	24.1%	Yes	FACU
<i>Climbing Woody Vine</i>					
<i>Ground Cover</i>					
Japanese-Knotweed	<i>Reynoutria japonica</i>	36%	78.3%	Yes	FACU
Goldenrod	<i>Solidago sp.</i>	10%	21.7%	Yes	NI

Remarks: * An asterisk after common plant name indicates stunted growth; ** indicates extremely stunted growth

Morphological Adaptations: 0 Description: _____

* An asterisk after indicator status denotes wetlands plants; plants listed in the Wetlands Protection Act (MGL c.131, s.40); plants in the genus Sphagnum; or plants listed as FAC, FACW, or OBL.

Vegetation conclusion:

Number of dominant wetland indicator plants: 0

Number of dominant non-wetland indicator plants: 4

Is the number of dominant wetland plants equal to or greater than the number of dominant non-wetland plants? no

If vegetation alone is presumed adequate to delineate the BVW boundary, submit this form with the Request for Determination of Applicability or Notice of Intent.

Section II. Indicators of Hydrology

Hydric Soil Interpretation

1. Soil Survey

Is there a published soil survey for this site? yes no

title/date: Soil Survey of Worcester County, Northeastern Part - 1985

map number: _____

soil type mapped: Merrimac fine sandy loam

hydric soil inclusions: _____

Are field observations consistent with soil survey? yes no

Remarks: _____

2. Soil Description

Horizon	Depth (inches)	Matrix Color	Mottles Color or Texture
A	1-10	10YR2/2	
B	10-20	10YR3/2	10YR5/6

Remarks: _____

3. Other:

Conclusion: Is soil hydric? yes no

Other Indicators of Hydrology: (check all that apply and describe)

- Site inundated: _____
- Depth to free water in observation hole: _____
- Depth to soil saturation in observation hole: _____
- Water marks: _____
- Drift Lines: _____
- Sediment deposits: _____
- Drainage patterns in BWV: _____
- Oxidized rhizospheres: _____
- Water-stained leaves: _____
- Recorded data (stream, lake, or tidal gauge; aerial photo; other): _____
- Other: _____

Vegetation and Hydrology Conclusion for Upgradient of A-11

Number of wetland indicator plants
 >= number of non-wetland plants

yes no

X

Wetland hydrology present:

hydric soils present

X

other indicators of hydrology present

X

Sample location is in a BWV

X

Submit this form with the Request for Determination of Applicability or Notice of Intent

DEP Bordering Vegetated Wetland (310 CMR 10.55) Delineation Field Data Form

Applicant: _____
 Check all that apply:

Prepared by: Steve Eriksen
 Vegetation alone presumed adequate to delineate BWV boundary: fill out Section I only
 Vegetation and other indicators of hydrology used to delineate BWV boundary: fill out Sections I and II
 Method other than dominance test used (attach additional information)

Project location: 0 Hudson St, Northboro

DEP File #: _____

Section I. Vegetation		Transect Number: Downgradient	Date of Delineation: 18-Aug-19
Sample Layer and Plant Species	Scientific name	% Cover	% Dominance
Tree Layer			Dominant Plant (yes or no)
Shrub Layer			Wetland Indicator Category*
<p><u>Sapling Layer</u></p>			
<p><u>Shrub Layer</u> Silky dogwood</p>	<i>Cornus amomum</i>	36%	100.0% Yes FACW*
<p><u>Climbing Woody Vine</u></p>			
<p><u>Ground Cover</u> Sensitive fern Sweet-scented Joe-pye-weed</p>	<i>Onoclea sensibilis</i> <i>Eutrochium purpureum</i>	63% 20%	75.9% 24.1% Yes Yes FACW* FAC*
<p>Remarks: * An asterisk after common plant name indicates stunted growth; ** indicates extremely stunted growth</p>			
<p>Morphological Adaptations: 0</p>			
<p>* An asterisk after indicator status denotes wetlands plants: plants listed in the Wetlands Protection Act (MGL c.131, s.40); plants in the genus Sphagnum; or plants listed as FAC, FACW, or OBL.</p>			
<p>Vegetation conclusion:</p>			
<p>Number of dominant wetland indicator plants: 3</p>			
<p>Is the number of dominant wetland plants equal to or greater than the number of dominant non-wetland plants? yes</p>			
<p>Number of dominant non-wetland indicator plants: 0</p>			
<p><i>If vegetation alone is presumed adequate to delineate the BWV boundary, submit this form with the Request for Determination of Applicability or Notice of Intent.</i></p>			

Section II. Indicators of Hydrology

Hydric Soil Interpretation

1. Soil Survey

Is there a published soil survey for this site? yes no

title/date: Soil Survey of Worcester County, Northeastern Part - 1985
map number: _____

soil type mapped: Wapole
hydric soil inclusions: _____

Are field observations consistent with soil survey? yes no
Remarks: _____

2. Soil Description

Horizon	Depth (inches)	Matrix Color	Mottles Color or Texture
O	1-10	10YR2/2	10YR5/6
C	10-20	10YR6/1	

Remarks: _____

3. Other: _____

Conclusion: Is soil hydric? yes no

Other Indicators of Hydrology: (check all that apply and describe)

- Site inundated: _____
- Depth to free water in observation hole: _____
- Depth to soil saturation in observation hole: _____
- Water marks: _____
- Drift Lines: _____
- Sediment deposits: _____
- Drainage patterns in BVW: _____
- Oxidized rhizospheres: _____
- Water-stained leaves: _____
- Recorded data (stream, lake, or tidal gauge; aerial photo; other): _____
- Other: _____

Vegetation and Hydrology Conclusion for Downgradient of A-11

	yes	no
Number of wetland indicator plants >= number of non-wetland plants	X	
Wetland hydrology present: hydric soils present	X	
other indicators of hydrology present	X	
Sample location is in a BVW	X	

Submit this form with the Request for Determination of Applicability or Notice of Intent

Legend

 Property_Boundary

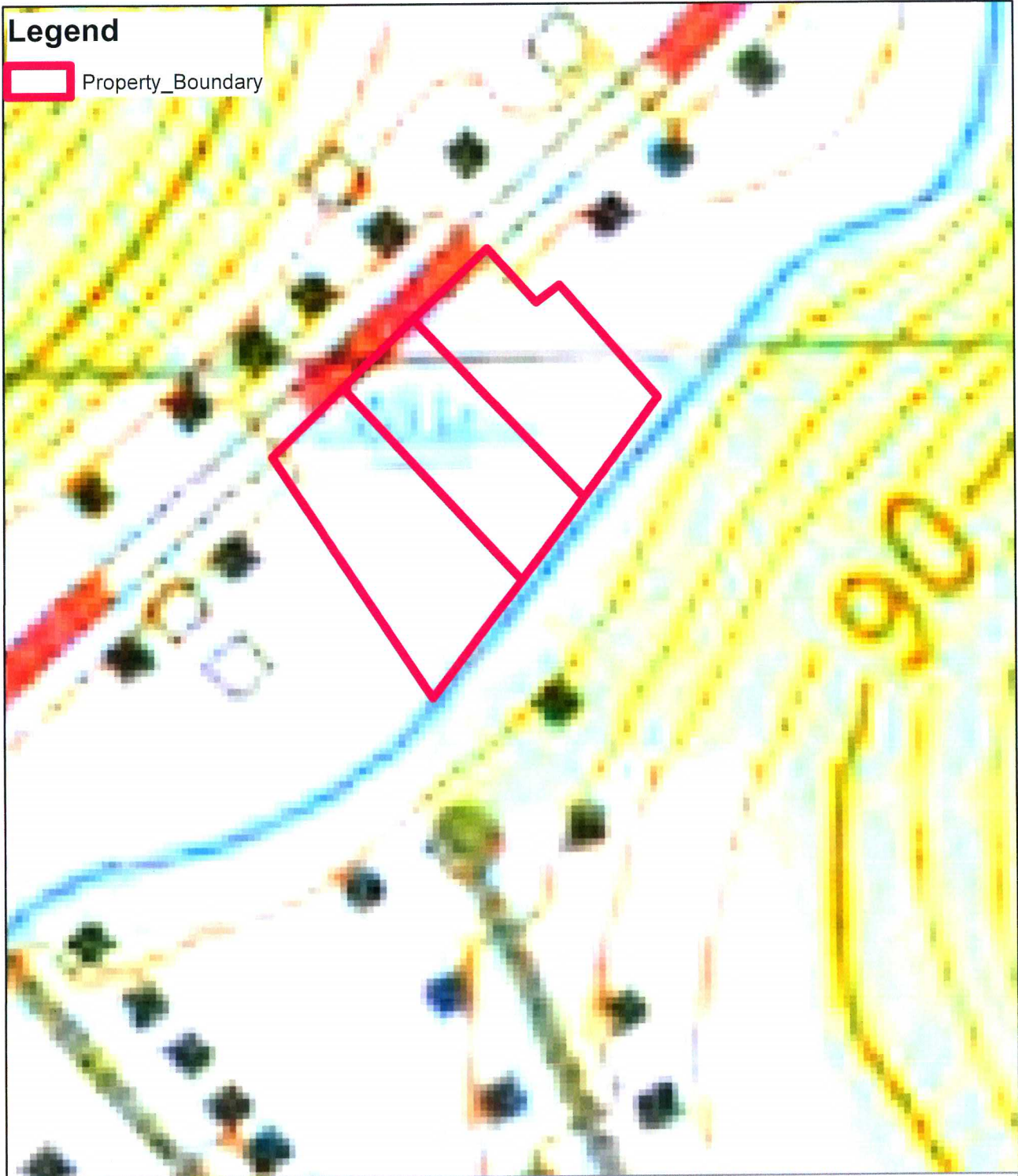

USGS Site Locus

0 Hudson Street, Northborough, MA 01532



1 inch = 150 feet
Date: 4/18/18

GIS Data Source: "Office of Geographic Information (MassGIS), Commonwealth of Massachusetts, MassIT"

Legend
Property_Boundary

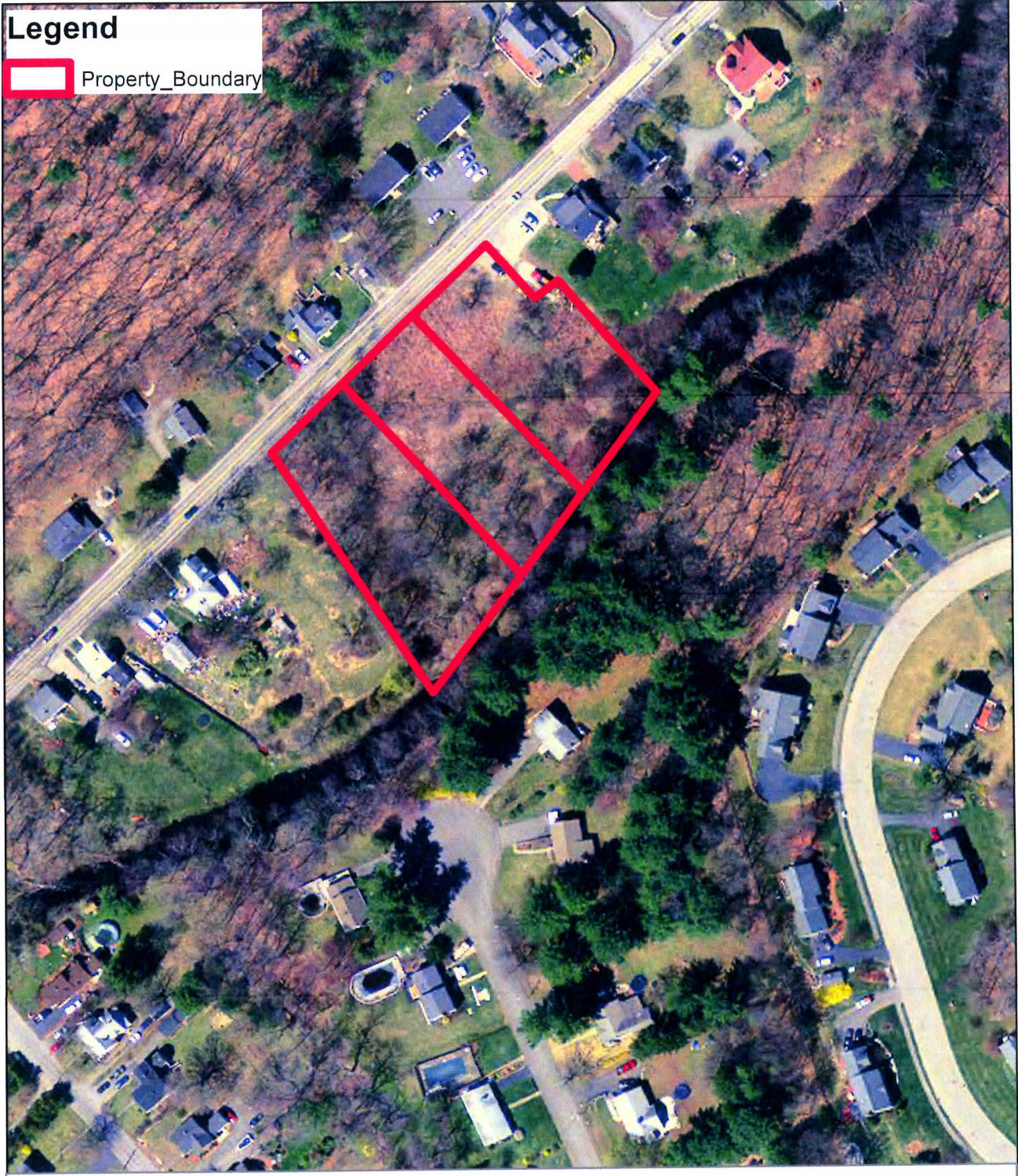

Ortho Image of Site

0 Hudson Street, Northborough, MA 01532

N
1 inch = 150 feet
Date: 4/18/18

GIS Data Source: "Office of Geographic Information (MassGIS), Commonwealth of Massachusetts, MassIT"



NORSE ENVIRONMENTAL SERVICES, INC.

92 Middlesex Road, Unit 4

Tyngsboro, MA 01879

TEL. (978) 649-9932 • FAX (978) 649-7582

Website: www.norseenvironmental.com

January 26, 2021

Northborough Conservation Commission
Northborough Town Hall
63 Main Street
Northborough, MA 01532

RE: Wildlife Habitat Evaluation

0 Hudson Street, Northborough, MA (Assessors Map 53; Lots 19, 20, 21)

1. Introduction

Norse Environmental Services, Inc is pleased to submit this Wildlife Habitat Evaluation (WHE) for the Notice of Intent (NOI) application filed on behalf of the applicant, Circle Assets LLC. The WHE has been prepared in accordance with the “Massachusetts Wildlife Habitat Protection Guidelines for Inland Wetlands” manual produced by the Mass Department of Environmental Protection (DEP), aka the “DEP manual.” The plans reviewed for the WHE are entitled “*Plan of 0 Hudson Street in, Northborough, MA* (3 sheets), Connorstone Engineering, 12/24/2020.

The proposed resource area impacts for this project include: BVW (520 SF), BLSF (22,390 SF) and Riverfront (22,218 SF). These resource areas overlap, therefore the overall footprint of the alteration is 26,021 SF. **Figure 1** illustrates the resource area impact areas.

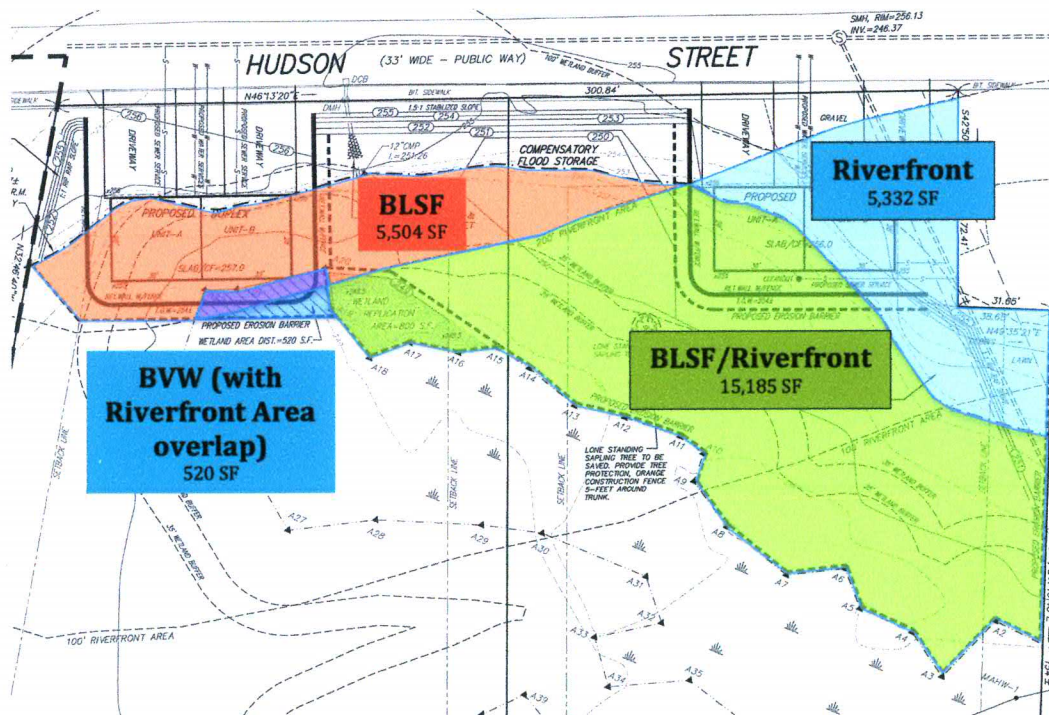

Figure 1: Project Impacts (Temp. and Permanent)

The alterations are proposed primarily to restore riverfront and BLSF that is current degraded with invasive species. Additional alterations are required for the construction of two duplexes and associated grading, retaining walls and driveways. The alterations trigger an Appendix B: Detailed Wildlife Habitat Assessment.

Steve Eriksen conducted the WHE with a site inspection that took place on February 27, 2019. Mr. Eriksen has decades of experience conducting wildlife habitat evaluations in Massachusetts. He therefore meets the criteria for conducting wildlife habitat evaluations listed in the WPA Regulations (310 CMR 10.60 (1)(b)).

This WHE will provide evidence that the project does not have a significant adverse effect on the “wildlife habitat” wetlands interest and value protected by the Act, and that the proposed mitigation will provide an improvement in wildlife habitat over the existing conditions by increasing the quality of native riverfront and BLSF that will provide valuable foraging and sheltering habitat to the local wildlife.

2. Existing Conditions of Impacted Resource Areas

Sheet 1 of the plans shows the existing conditions. **Figure 2** illustrates the large proportion of the site that is infested with Japanese knotweed (tan hatched area):

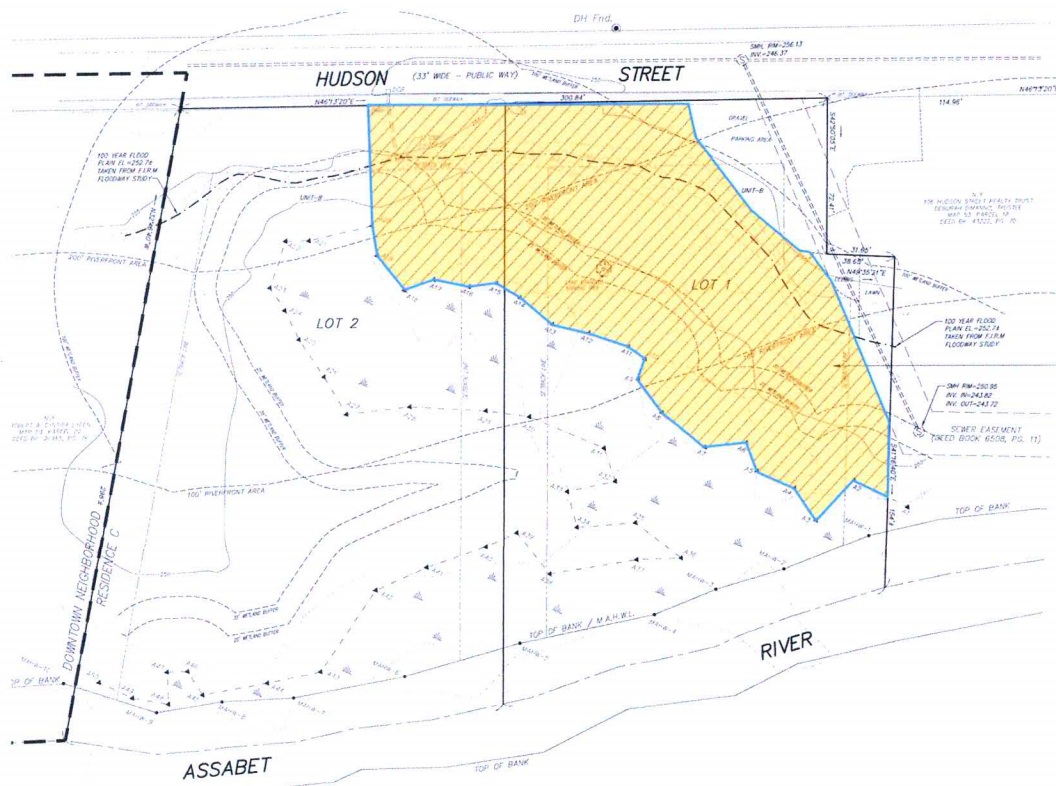

Figure 2: The tan shaded area of the site plan is entirely infested with Japanese knotweed.

This knotweed area is 18,260 SF in extent and is found in both BLSF and Riverfront Area resource areas. It comprises the majority of the 22,471 SF area to be altered. The remaining 4,211 SF of the resource area alteration will be to create habitat that is much more natural in

character (Photos 5-6), with the exception of some invasive honeysuckle shrubs.

2.1 Resource Areas within Lot 1 (eastern half of site)

Photos 1-3 show the existing conditions and highlight the Japanese knotweed infestation within BLSF/Riverfront within Lot 1.



Photo 1 – Center of Lot 1, looking east along wetland line



Photo 2 – Center of Lot 1, looking north along wetland line.



Photo 3 – Center of Lot 1, looking west along wetland line.

The southeast corner of Lot 1 has some natural vegetation which includes pockets of dense herbaceous cover consisting of sensitive fern, plus silky dogwood and blackberry shrubs (**Photo 4**). A single, large, speckled alder shrub and single black walnut tree (**Photo 5**) are also present within this area. Outside of this area, the rest of the upland area on lot 1 is nearly 100% Japanese Knotweed.



Photo 4 – South end of Lot 1, blackberry shrub.



Photo 5 – Center of Lot 1, black walnut tree.

2.2 Resource Areas within Lot 2 (western half of site).

The northeast corner of Lot 2 is nearly 100% Japanese Knotweed. West of wetland flag #A20 there is a greater variety of plants, but among them is invasive honeysuckle (**Photo 6**). The north-center and northwest corner of Lot 2 is a sparse area of honeysuckle, silky dogwood and sensitive fern (**Photo 7**). Trees in the area consists of red maple, American elm and ash. Some areas contain small dense clumps of sensitive fern. The small portion of BVW to be altered in Lot 2 includes dense sensitive ferns and native shrubs.



Photo 6 – Center of Lot 2 near WF #A18, looking south into wetland.



Photo 7 – North-center of Lot 2 at WF #22, looking northwest towards Hudson Street.

3. Project Description

Lot 1

The applicant is proposing a duplex unit on Lot 1 within an already degraded gravel parking lot area and on the outer part of the Riverfront Area. This degraded area has Japanese Knotweed growing from the edge of the gravel area to the edge of the wetland. The proposed permanent alteration is 4,735 SF while restoring 16,560 SF of riverfront area to natural riverfront by removing Japanese knotweed through an invasive species management plan (see attached). The proposed grading will provide compensatory storage for all BLSF alteration (see site plans for cut/fill calculations)

Lot 2

The applicant is proposing a duplex unit on Lot 2 that has all development nearly all out of Riverfront Area with the exception of a small section of a retaining wall and the wetland replication area. Although the proposal does result in wetland impacts, the net impact to resource areas is greatly reduced by the proposed location. The wetlands impacted is 520 SF, while a replication area of 800 SF is proposed. The proposed permanent alteration to Riverfront Area is 110 SF while restoring 1,700 SF of riverfront area to natural riverfront by removing Japanese knotweed through an invasive species management plan (see attached). The proposed grading will provide compensatory storage for all BLSF alteration (see site plans for cut/fill calculations). The applicant also proposes to install proper rip-rap below the stormwater pipe that discharges on to the lot to stop erosion of soil which is currently occurring during storms.

4. Evaluation of Impacts to Wildlife Habitat

BVW

The BVW alteration area does not contain any significant wildlife habitat features such as food-bearing shrubs, woody debris, dead snags or dense vegetation coverage. It does not likely hold standing water for significant periods of time to provide habitat for amphibians or turtles.

Riverfront

The project will not impact any significant wildlife habitat features such as dead snags, mammal dens, or dense natural vegetation. The area of riverfront impacted is nearly all Japanese Knotweed.

BLSF

The project will not impact any significant wildlife habitat features such as dead snags, mammal dens, or dense natural vegetation. The area of BLSF impacted is nearly all Japanese Knotweed.

5. Proposed Mitigation Details

The proposed *Wetland Replication, Compensatory Storage, and Invasive Species Management Plans* provide details on how work will be conducted. These documents were included with the NOI submittal. The mitigation includes the removal of nearly 18,260 SF (Lot 1 - 16,560 SF, Lot 2 – 1,700 SF) of Japanese Knotweed and the restoration of natural meadow habitat. The invasive species removal, BLSF compensation, and BVW replication equate to 21,288 SF of mitigation for the site. A lone, standing nut-bearing tree above wetland flag A12 will be protected. Lastly,

the ISMP also includes native shrub plantings to provide for shrub thickets within the restored meadow area.

6. Conclusions

- No unique or uncommon wildlife habitat features will be eliminated for construction of the project.
- None of the trees to be removed contain any obvious nesting cavities, and there will be many trees that remain outside of the work area throughout the site.
- There are important habitat features present outside of the project area (dense herbaceous cover, nut-and-berry-producing plants, rotting logs/woody debris, etc.) within the site's undeveloped wetland and upland resource areas.
- Enhancement by removing 18,260 SF of invasive BLSF and Riverfront to 21,103 SF of natural meadow with shrub thickets.
 - This will provide increase capacity for the resource areas to function naturally
 - This will increase the area of natural wildlife habitat.
- Preservation of native shrubs from the proposed disturbed areas to be saved in place or transplanted back into place will add to the diversity of the restored habitat.
- Wetlands will be replicated at a 1.5:1 ratio with native shrubs, ferns and trees, which will more than compensate for the small amount of BVW fill.
- Removal and monitoring of invasive species (18,260 SF) will provide native habitat of over 21,103 SF.
- The onsite BVW will continue to function as it has prior to proposed development and will be protected by removal of invasive species.
- A large area (6,338 SF) of the inner riparian zone, which is currently degraded by the abundance of invasive species, will be greatly enhanced upon the completion of the project.

Based on the above, we conclude that the proposed alteration of the BVW, BLSF and Riverfront will not result in an impairment of the capacity of any of these resource areas to provide any important wildlife habitat functions.

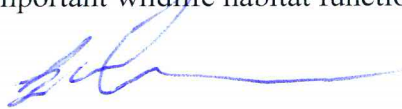

Steve Eriksen
Norse Environmental Services, Inc



Wildlife Habitat Protection Guidance

Appendix B: Detailed Wildlife Habitat Evaluation

Part 1. Summary Sheet

Important: When filling out forms on the computer, use only the tab key to move your cursor - do not use the return key.

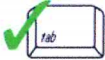

0 Hudson Street NOI
 Project Name
 0 Hudson Street, Northborough, MA (Map 53, Lots 19,20 & 21)
 Location
 520 SF BVW, 21,470 BLSF, 21,120 Riverfront (Note: BLSF and riverfront overlap in area) 2/27/19
Date

Impact Areas (linear feet, square feet, or acres for each of the impact areas within the site)

Name	Waterbody/ Waterway	Wetland	Upland*	Total Area
1. BVW		520 SF		520 SF
2. BLSF			22,390 SF*	22,390 SF
3. Riverfront	Assabet River	520SF	25,078 SF*	25,078 SF
4.				
5.			Total:	26,021* SF
6.				
7.				

*Note: BLSF and Riverfront overlap in area

Attach Sketch map and/or photos of the Impact Areas

Narrative Description of Site (attach separate page if necessary)

See attached Wildlife Habitat Evaluation letter.

Certification

I hereby certify that this project has been designed to avoid, minimize, and mitigate adverse effects on wildlife habitat, and that it will not, following two growing seasons of project completion and thereafter, substantially reduce its capacity to provide important wildlife habitat functions.

Signature of Wildlife Specialist (per 310 CMR 10.60 (1) (b))

Typed or Printed Name

Signature of Wildlife Specialist (per 310 CMR 10.60 (1) (b))

Typed or Printed Name



Wildlife Habitat Protection Guidance

Appendix B: Detailed Wildlife Habitat Evaluation

Part 2. Field Data Form (for each wetland or non-wetland resource area)

I. General Information

0 Hudson Street, Northborough, MA (Map 53, Lots 19,20 & 21)

Project Location (from NOI page 1)

BVW, BLSF and Riverfront Combined (Note: BLSF and Riverfront overlap in area)

Impact Area (number/name)

8/1/19

Date(s) of Site Visit(s) and Data Collection

Partly Cloudy, low 20s, Some 1-2" snow/ice cover

Weather Conditions During Site Visit (if snow cover, include depth)

Steve Erikson

8/18/19

Person completing form per 310 CMR 10.60(1)(b)

Date this form was completed

8/18/19

Person completing form per 310 CMR 10.60(1)(b)

Date this form was completed

The information on this data sheet is based on my observations unless otherwise indicated

Signature

Signature

II. Site Description (complete A or B under Classification - see instructions for full description)

A. Classification

1. For Wetland Resource Areas, complete the following:

System: Palustrine Subsystem: NA

Class: Scrub-Shrub / Forested Subclass: Broad-Leaved Deciduous / Deciduous

Hydrology/Water Regime

Permanently flooded

Saturated

Intermittently exposed

Temporarily flooded

Semi-permanently flooded

Intermittently flooded

Seasonally flooded

Artificially flooded

2. For Riverfront or Bordering Land Subject to Flooding Resource Areas, complete the following.

Use a terrestrial classification system such as one of the two listed below:

a. "Classification of the Natural Communities of Massachusetts (Draft)" by Patricia C. Swain and Jennifer B. Kearsley, MA DFW NHESP, Westborough, MA. July 2000. ([Department of Fish & Game Website](#))

b. "New England Wildlife: Habitat, Natural History, and Distribution" by Richard M. DeGraaf and Deborah D. Rudis, USDA Forest Service, Northeastern Forest Experiment Station. General Technical Report NE-108. August 1992. 491 pages.

Palustrine

Community Name

Forested Wetland / Floodplain Forested

Vegetation Description

Scrub-Shrub / Forested

Physical Description



Wildlife Habitat Protection Guidance

Appendix B: Detailed Wildlife Habitat Evaluation

Part 2. Field Data Form (continued)

B. Inventory (Plant community)

% Cover: 33% 80%* 33%
 Trees (> 20') Shrubs (< 20') Woody vines Mosses Herbaceous

Plant Lists (species that comprise 10% or more of the vegetative cover in each strata; "*" designates a dominant plant species for the strata):

Strata	Plant Species	Strata	Plant Species
Trees	Red Maple, Elm, Ash		
Tree - Sapling	Black walnut		
Shrub	silky dogwood, blackberry		
Shrub	Honeysuckle		
Shrub	Japanese Knotweed	(80% of proposed disturbance)	
Herbaceous	Sensitive Fern		

*invasive species cover included

C. Inventory (Soils)

<u>Merrimac fine sandy loam</u>	<u>Hydrologic soil group: A</u>
<u>Soil Survey Unit</u>	<u>Drainage Class</u>
<u>Sandy loam</u>	<u>20"</u>
<u>Texture (upper part)</u>	<u>Depth</u>
<u>16"</u>	
<u>Depth to Water Table</u>	

III. Important Habitat Features (complete for all resource areas)

If the following habitat characteristics are present, describe & quantify them on a separate sheet & attach.

Wildlife Food

Important Wetland/Aquatic Food Plants (smartweeds, pondweeds, wild rice, bulrush, wild celery)

Abundant Present Absent

Important Upland/Wetland Food Plants (hard mast and fruit/berry producers)

Abundant Present Absent

Shrub thickets or streambeds with abundant earthworms (American woodcock)

Present Absent

Shrub and/or herbaceous vegetation suitable for veery nesting

Present Absent

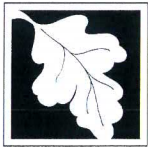

Wildlife Habitat Protection Guidance

Appendix B: Detailed Wildlife Habitat Evaluation

Part 2. Field Data Form (continued)

Number of trees (live or dead) > 30" DBH: None

Number (or density) of Standing Dead Trees (potential for cavities and perches):

 6-12" dbh 12-18" dbh 18-24" dbh > 24" dbh

Number of Tree Cavities in trunks or limbs of:

None
6-12" diameter (e.g., tree swallow, saw whet owl, screech owl, bluebird, other songbirds)

None
12-18" diameter (e.g., hooded merganser, wood duck, common goldeneye, mink)

None
>18" diameter (e.g., hooded merganser, wood duck, common goldeneye, common merganser, barred owl, mink, raccoon, fisher)

Small mammal burrows

Abundant Present Absent

Cover/Perches/Basking/Denning/Nesting Habitat

Dense herbaceous cover (voles, small mammals, amphibians & reptiles)

Large woody debris on the ground (small mammals, mink, amphibians & reptiles)

Rocks, crevices, logs, tree roots or hummocks under water's surface (turtles, snakes, frogs)

Rocks, crevices, fallen logs, overhanging branches or hummocks at, or within 1m above the water's surface (turtles, snakes, frogs, wading birds, wood duck, mink, raccoon)

Rock piles, crevices, or hollow logs suitable for:

otter mink porcupine bear bobcat turkey vulture

Live or dead standing vegetation overhanging water or offering good visibility of open water (e.g., osprey, kingfisher, flycatchers, cedar waxwings)

Depressions that may serve as seasonal (vernal/autumnal) pools

Present Absent

Standing water present at least part of the growing season, suitable for use by

Breeding amphibians Non-breeding amphibians (foraging, re-hydration)

Turtles Foraging waterfowl

Sphagnum hummocks or mats, moss-covered logs or saturated logs, overhanging or directly adjacent to pools of standing water in spring (four-toed salamander)

Present Absent



Wildlife Habitat Protection Guidance

Appendix B: Detailed Wildlife Habitat Evaluation

Part 2. Field Data Form (continued)

Important habitat characteristics (if present, describe and quantify them on a separate sheet)

Medium to large (> 6"), flat rocks within a stream (cover for stream salamanders and nesting habitat for spring & two-lined salamanders)

Present Absent

Flat rocks and logs on banks or within exposed portions of streambeds (cover for stream salamanders and nesting habitat for dusky salamanders)

Present Absent

Underwater banks of fine silt and/or clay (beaver, muskrat, otter)

Present Absent

Undercut or overhanging banks (small mammals, mink, weasels)

Present Absent

Vertical sandy banks (bank swallow, kingfisher)

Present Absent

Areas of ice-free open water in winter

Present Absent

Mud flats

Present Absent

Exposed areas of well-drained, sandy soil suitable for turtle nesting

Present Absent

Wildlife dens/nests (if present, describe & quantify them on the back of this sheet)

Turtle nesting sites

Present Absent

Bank swallow colony

Present Absent

Nest(s) present of

Bald Eagle Osprey Great Blue Heron

Den(s) present of

Otter Mink Beaver



Wildlife Habitat Protection Guidance

Appendix B: Detailed Wildlife Habitat Evaluation

Part 2. Field Data Form (continued)

Project area is within:

- 100' of beaver, mink or otter den, bank swallow colony or turtle nesting area
- 200' of Great Blue Heron or osprey nest(s)
- 1400' of a Bald Eagle nest¹

Emergent Wetlands (if present, describe & quantify them on a separate sheet)

Emergent wetland vegetation at least seasonally flooded during the growing season (wood duck, green heron, black-crowned night heron, king rail, Virginia rail, coot, etc.)

Flooded > 5 cm Present Absent

Flooded > 25 cm (pied-billed grebe) Present Absent

Persistent emergent wetland vegetation at least seasonally flooded during the growing season (mallard, American bittern, sora, common snipe, red-winged blackbird, swamp sparrow, marsh wren)

Flooded > 5 cm Present Absent

Flooded > 25 cm (least bittern, common moorhen) Present Absent

Cattail emergent wetland vegetation at least seasonally flooded during the growing season

Flooded > 5 cm (marsh wren) Present Absent

Flooded > 25 cm (least bittern, common moorhen) Present Absent

Fine-leafed emergent vegetation (grasses and sedges) at least seasonally flooded during the growing season (common snipe, spotted sandpiper, sedge wren)

Flooded > 5 cm Present Absent

Flooded > 25 cm (least bittern, common moorhen) Present Absent

IV. Landscape Context

A. **Habitat Continuity** (if present, describe the landscape context on a separate sheet and its importance for area-sensitive species)

- | | | | |
|---|---------------------|------------------------------|--|
| Is the impact area part of an emergent marsh at least | 1.0 acre in size? | <input type="checkbox"/> Yes | <input checked="" type="checkbox"/> No |
| (marsh and waterbirds) | 2.0 acres in size? | <input type="checkbox"/> Yes | <input checked="" type="checkbox"/> No |
| | 5.0 acres in size? | <input type="checkbox"/> Yes | <input checked="" type="checkbox"/> No |
| | 10.0 acres in size? | <input type="checkbox"/> Yes | <input checked="" type="checkbox"/> No |

¹ 1400 feet is the distance used by NHESP for evaluating potential disturbance impacts on eagle nests under MESA. Keep in mind, however, that this doesn't give jurisdiction within 1400' of an eagle's nest; it only identifies it on the checklist so that adverse effects can be avoided if work in a resource area is within 1400 feet.



Wildlife Habitat Protection Guidance

Appendix B: Detailed Wildlife Habitat Evaluation

Part 2. Field Data Form (continued)

- | | | | |
|---|---------------------|------------------------------|--|
| Is the impact area part of a wetland complex at least | 2.5 acres in size? | <input type="checkbox"/> Yes | <input checked="" type="checkbox"/> No |
| (turtles, frogs, waterfowl, mammals) | 5.0 acres in size? | <input type="checkbox"/> Yes | <input checked="" type="checkbox"/> No |
| | 10.0 acres in size? | <input type="checkbox"/> Yes | <input checked="" type="checkbox"/> No |
| | 25.0 acres in size? | <input type="checkbox"/> Yes | <input checked="" type="checkbox"/> No |
| For upland resource areas is the impact area part of contiguous forested habitat at least | | | |
| (forest interior nesting birds) | 50 acres in size? | <input type="checkbox"/> Yes | <input checked="" type="checkbox"/> No |
| | 100 acres in size? | <input type="checkbox"/> Yes | <input checked="" type="checkbox"/> No |
| | 250 acres in size? | <input type="checkbox"/> Yes | <input checked="" type="checkbox"/> No |
| | 500 acres in size? | <input type="checkbox"/> Yes | <input checked="" type="checkbox"/> No |
| (grassland nesting birds) | > 1.0 acre in size? | <input type="checkbox"/> Yes | <input checked="" type="checkbox"/> No |
| (special habitat such as gallery floodplain forest, alder thicket, etc.) | > 1.0 acre in size? | <input type="checkbox"/> Yes | <input checked="" type="checkbox"/> No |

B. Connectivity with adjoining natural habitats

- No direct connections to adjacent areas of wildlife habitat (little connectivity function)
- Connectors numerous or impact area is embedded in a large area of natural habitat (limited connectivity function)
- Impact area contributes to a limited number of connectors to adjacent areas of habitat (somewhat important for connectivity function)
- Impact area serves as *part of* a sole connector to adjacent areas of habitat (important for connectivity function)
- Impact area serves as *only* connector to adjacent areas of habitat (very important for connectivity function)

V. Habitat Degradation (describe degradation and wildlife impacts on the back of the sheet)

- Evidence of significant chemical contamination
- Evidence of significant levels of dumping
- Evidence of significant erosion or sedimentation problems
- Significant invasion of exotic plants (e.g., **Japanese Knotweed**)
- Disturbance from roads or highways
- Other human disturbance
- Is the site the only resource area in the vicinity of an otherwise developed area

Note: These are not the only important habitat features that may be observed on a site. If the wildlife specialist identifies other features they should be noted in the application.



Wildlife Habitat Protection Guidance

Appendix B: Detailed Wildlife Habitat Evaluation

Part 2. Field Data Form (continued)

VI. Quantification Table for Important Habitat Characteristics

Habitat Characteristic	Amount Impacted in Impact Area	Current (entire site)	Post-Construction (entire site)
Lone standing nut bearing tree	1 (to be preserved)	1 or more	1 or more
Important wildlife food	Sparse	Moderate density	Abundant due to invasive removal and revegetation with native species.

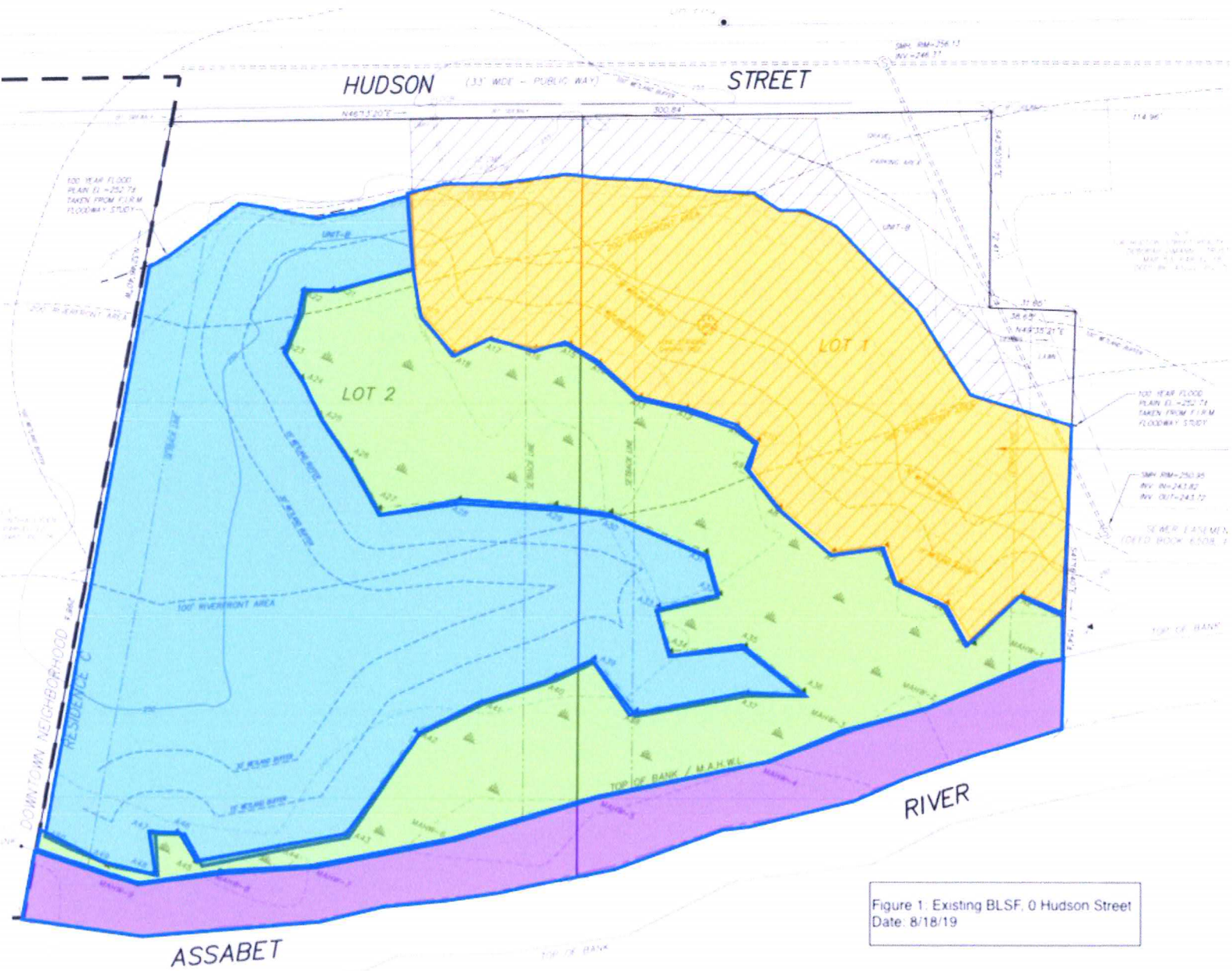

Figure 1: Existing BLSF, 0 Hudson Street
Date: 8/18/19

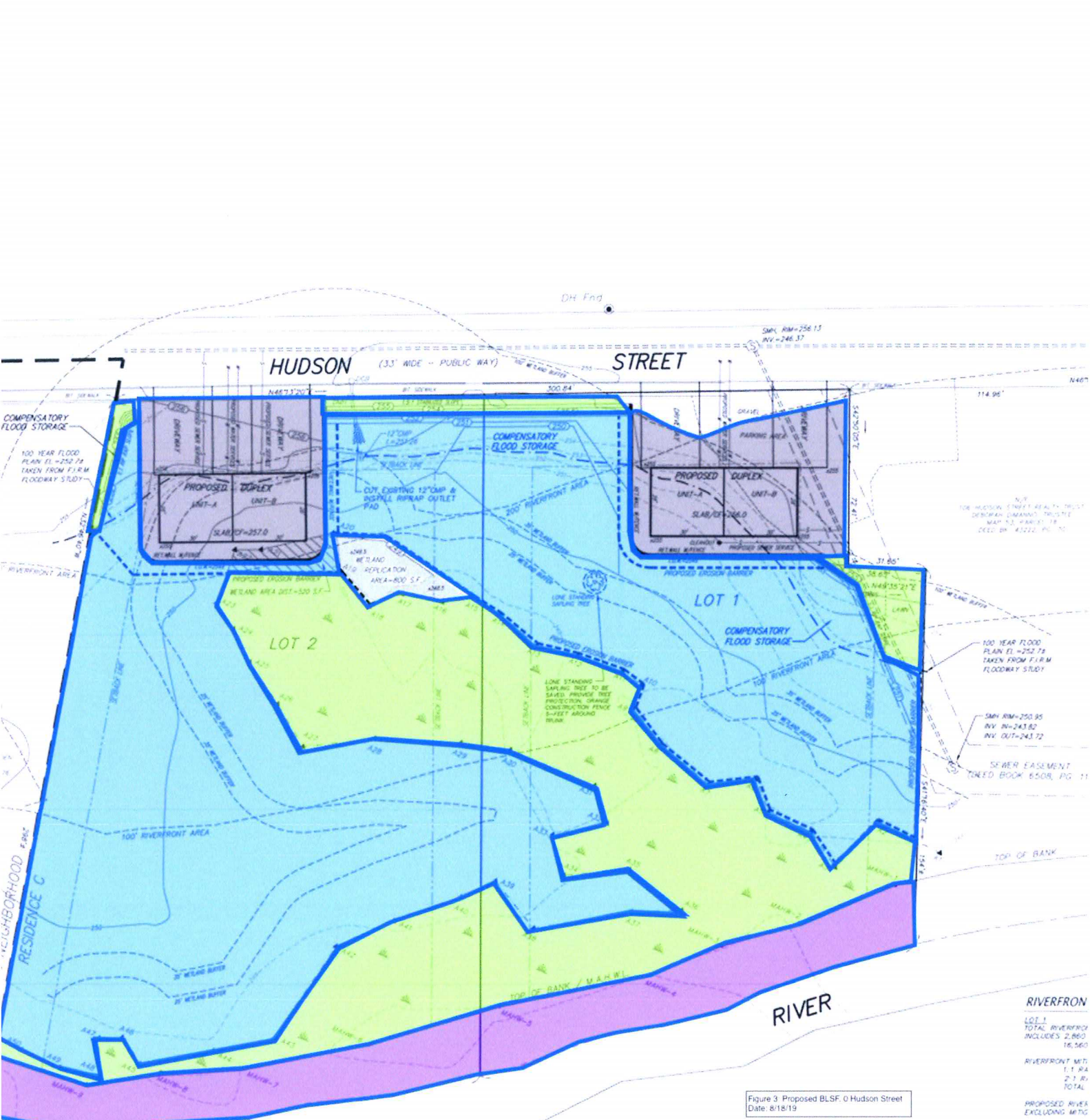

Figure 3 Proposed BLSF, 0 Hudson Street
Date: 8/18/19

RIVERFRON	
LOT 1	TOTAL RIVERFRONT INCLUDES 2,860
	16,560
RIVERFRONT MIT:	1.1 RA
	2.1 R
TOTAL	PROPOSED RIVER EXCLUDING MITG

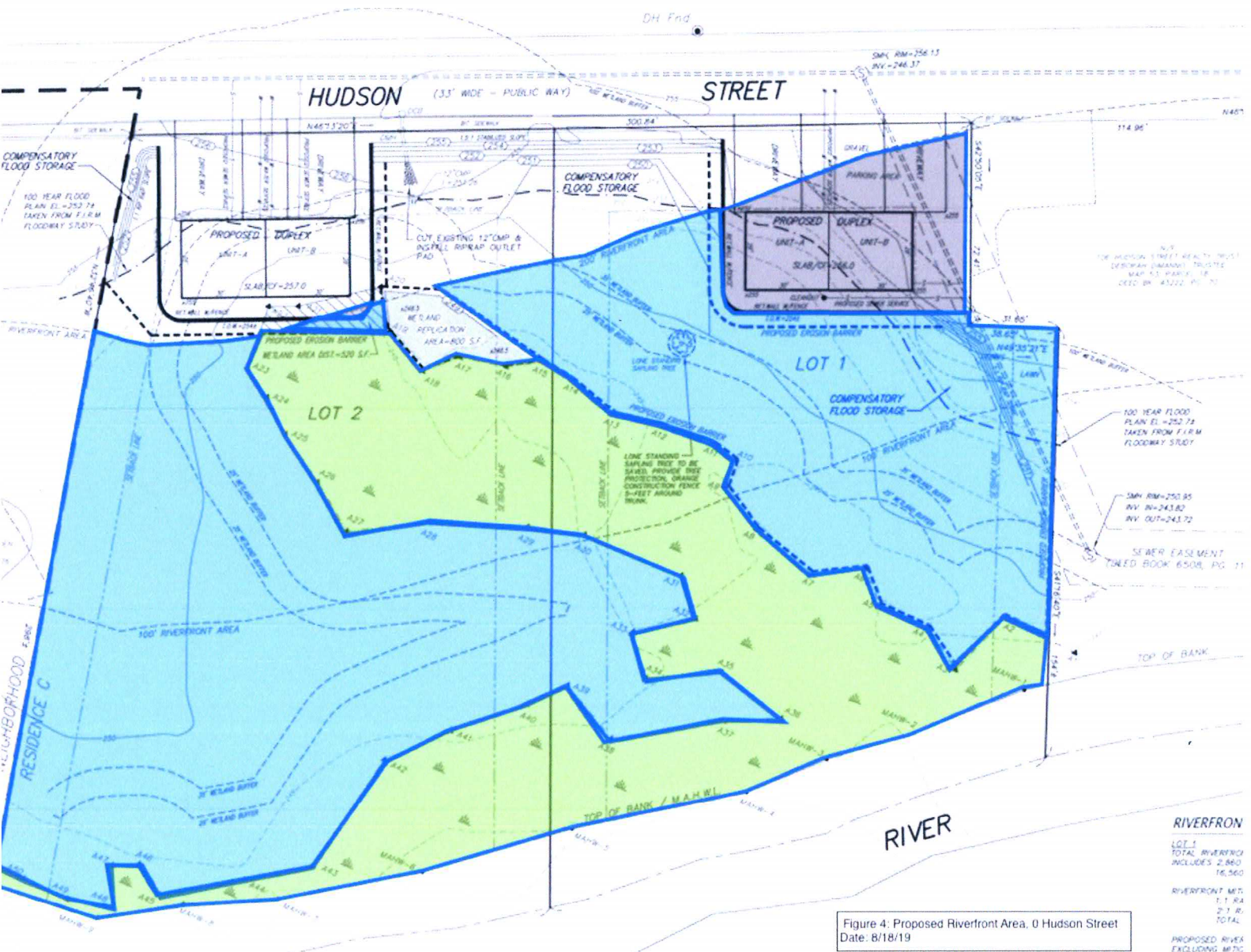
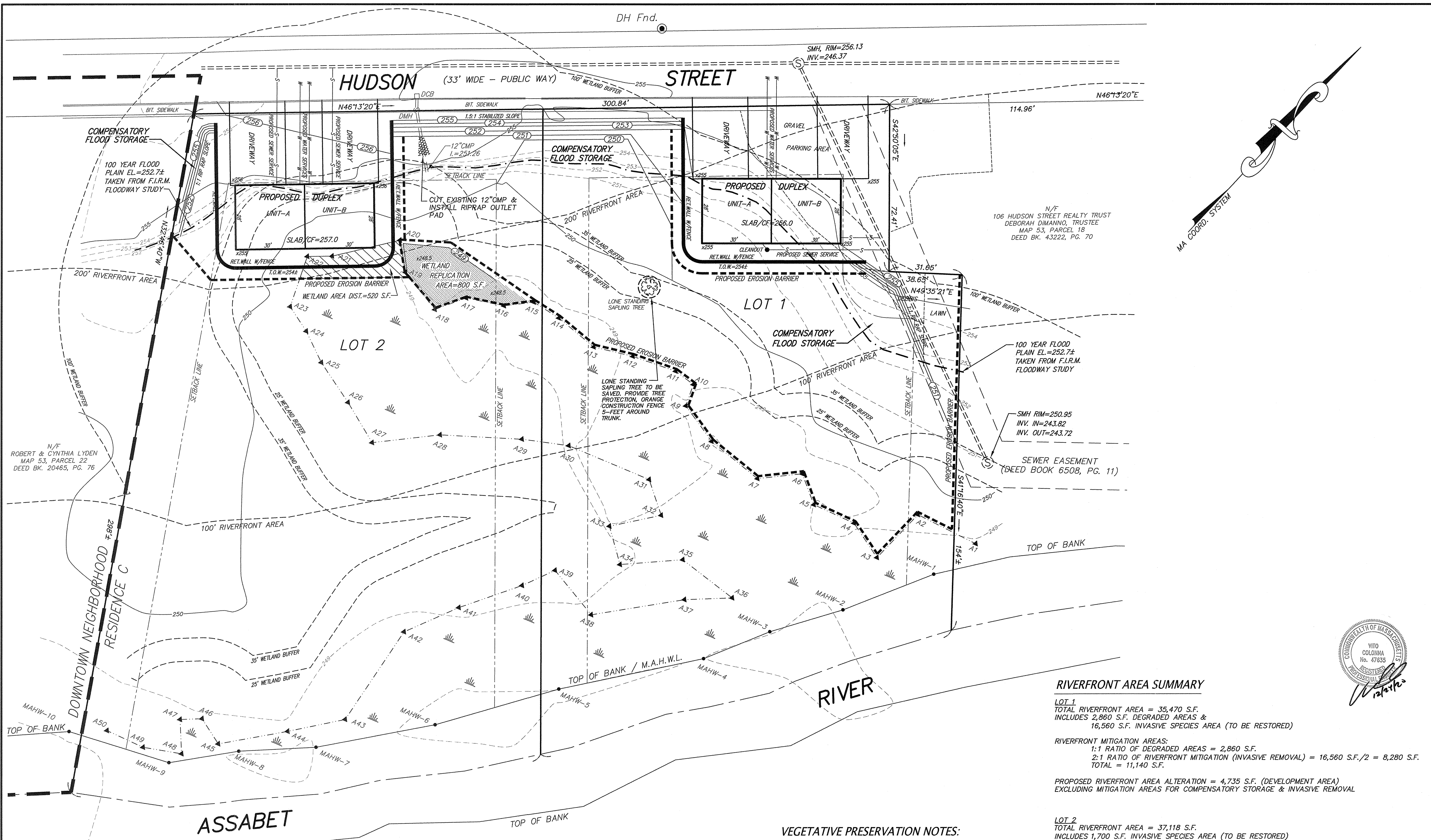

Figure 4: Proposed Riverfront Area, 0 Hudson Street
Date: 8/18/19



LEGEND

- UTILITY POLE
- ⊙ EXISTING DMH
- EXISTING DCB
- DCB ● PROPOSED CATCH BASIN
- DMH ● PROPOSED MANHOLE
- TREELINE
- 300 — 10' CONTOUR
- 302 — 2' CONTOUR
- 257.5 — SPOT GRADE
- (268) — FINISH GRADE
- WATER
- WATER GATE
- OHW — OVERHEAD WIRES
- GAS
- DRAIN
- SEWER
- EXISTING DRAIN
- ZONING SETBACK
- PROPOSED HAYBALES
- DTH-7 ● SOIL TEST HOLE

ZONED: RESIDENCE C "RC"
 GROUNDWATER PROTECTION OVERLAY 3
 AREA = 20,000 sf
 FRONTAGE = 100 feet
 LOT WIDTH = 100 feet
 SETBACKS: FRONT = 30 feet
 SIDE = 15 feet
 REAR = 25 feet

TWO FAMILY DWELLINGS
 AREA = 30,000 sf
 FRONTAGE = 150 feet
 LOT WIDTH = 150 feet
 SETBACKS: FRONT = 30 feet
 SIDE = 20 feet
 REAR = 25 feet

OWNER / APPLICANT:
 CIRCLE ASSETS, LLC
 291 MAIN STREET, SUITE 8
 NORTHBOROUGH, MA

CONNORSTONE ENGINEERING INC.
 CIVIL ENGINEERS AND LAND SURVEYORS
 10 SOUTHWEST CUTOFF, SUITE 7
 NORTHBOROUGH, MASSACHUSETTS 01532
 PHONE: 508-393-9727 FAX: 508-393-5242

PROPOSED SITE PLAN OF 100 HUDSON STREET IN NORTHBOROUGH, MA

REVISED:	DESCRIPTION:
DRAWN BY: REM	CHECK BY: VC
DATE: DECEMBER 24, 2020	
SCALE: 1"=20'	SHEET 2 OF 3.

RIVERFRONT AREA SUMMARY

LOT 1
 TOTAL RIVERFRONT AREA = 35,470 S.F.
 INCLUDES 2,860 S.F. DEGRADED AREAS & 16,560 S.F. INVASIVE SPECIES AREA (TO BE RESTORED)

RIVERFRONT MITIGATION AREAS:
 1:1 RATIO OF DEGRADED AREAS = 2,860 S.F.
 2:1 RATIO OF RIVERFRONT MITIGATION (INVASIVE REMOVAL) = 16,560 S.F./2 = 8,280 S.F.
 TOTAL = 11,140 S.F.

PROPOSED RIVERFRONT AREA ALTERATION = 4,735 S.F. (DEVELOPMENT AREA)
 EXCLUDING MITIGATION AREAS FOR COMPENSATORY STORAGE & INVASIVE REMOVAL

LOT 2
 TOTAL RIVERFRONT AREA = 37,118 S.F.
 INCLUDES 1,700 S.F. INVASIVE SPECIES AREA (TO BE RESTORED)

RIVERFRONT MITIGATION AREAS:
 2:1 RATIO OF RIVERFRONT MITIGATION (INVASIVE REMOVAL) = 1,700 S.F./2 = 850 S.F.

RIVERFRONT AREA ALTERATION = 225 S.F. (0.6%)
 EXCLUDING MITIGATION AREAS FOR INVASIVE REMOVAL & WETLAND REPLICATION

B.L.S.F. & COMPENSATORY FLOOD STORAGE CALCULATIONS:

TOTAL BORDERING LAND SUBJECT TO FLOODING (BLSF) ALTERATION AREA = 21,470 S.F.
 (EXCLUDES WETLAND ALTERATION & REPLICATION AREAS)

CONTOUR ELEVATION (FEET)	CUT/FILL STORAGE VOLUME SUMMARY (CUBIC FEET)			
	FILL	CUT (COMPENSATORY)	INCREMENTAL INCREASE	CUMULATIVE INCREASE
250-251	1,893	2,389	+496	+496
251-252	3,105	4,187	+1,082	+1,578
252-252.7	2,554	2,555	+1	+1,579

VEGETATIVE PRESERVATION NOTES:

1. LONE STANDING SAPLING TREE TO BE SAVED, PROVIDE TREE PROTECTION, ORANGE CONSTRUCTION FENCE 5- FEET AROUND TRUNK.
2. THE PROJECT WETLAND SCIENTIST SHALL FLAG SHRUBS TO BE TRANSPLANTED PRIOR TO EARTH DISTURBANCE.

GENERAL NOTES:

1. PROPERTY LINES ARE BASED UPON EXISTING PLANS AND DEEDS OF RECORD AND DOES NOT REPRESENT A PROPERTY SURVEY. A SEPARATE APPROVAL NOT REQUIRED (ANR) PLAN IS REQUIRED FOR CREATION OF THE TWO LOTS SHOWN HEREON.
2. EXISTING TOPOGRAPHY IS BASED UPON AN ON-GROUND TOPOGRAPHICAL SURVEY BY CONNORSTONE ENGINEERING, INC. IN JULY 2018. ELEVATIONS REFER TO NAVD 1988.
3. THE PARCEL IS LOCATED AT 100 HUDSON STREET, AS SHOWN ON ASSESSORS MAP 53, PARCELS 19, 20, 21.
4. WETLAND DELINEATION BY NORSE ENVIRONMENTAL SERVICES, LLC.

GRAPHIC SCALE: 1"=20'

0 5 10 15 20 25 30 40 50 75 100 FEET

0 5 10 15 20 25 30 METERS



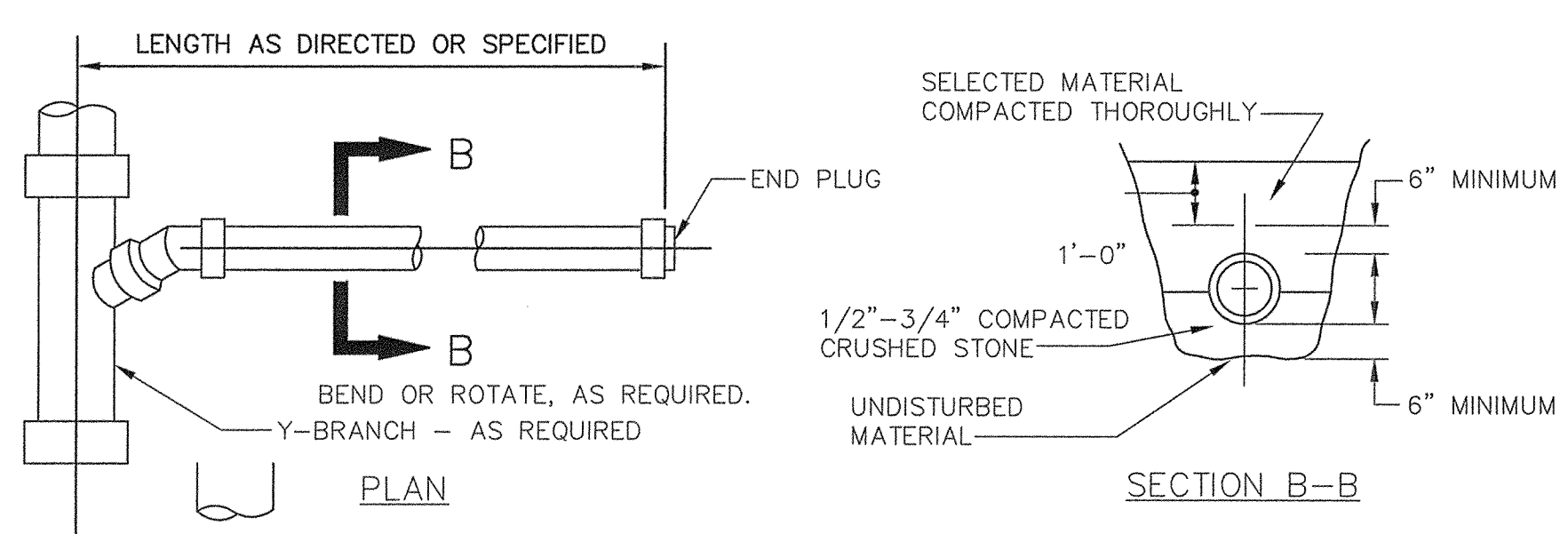
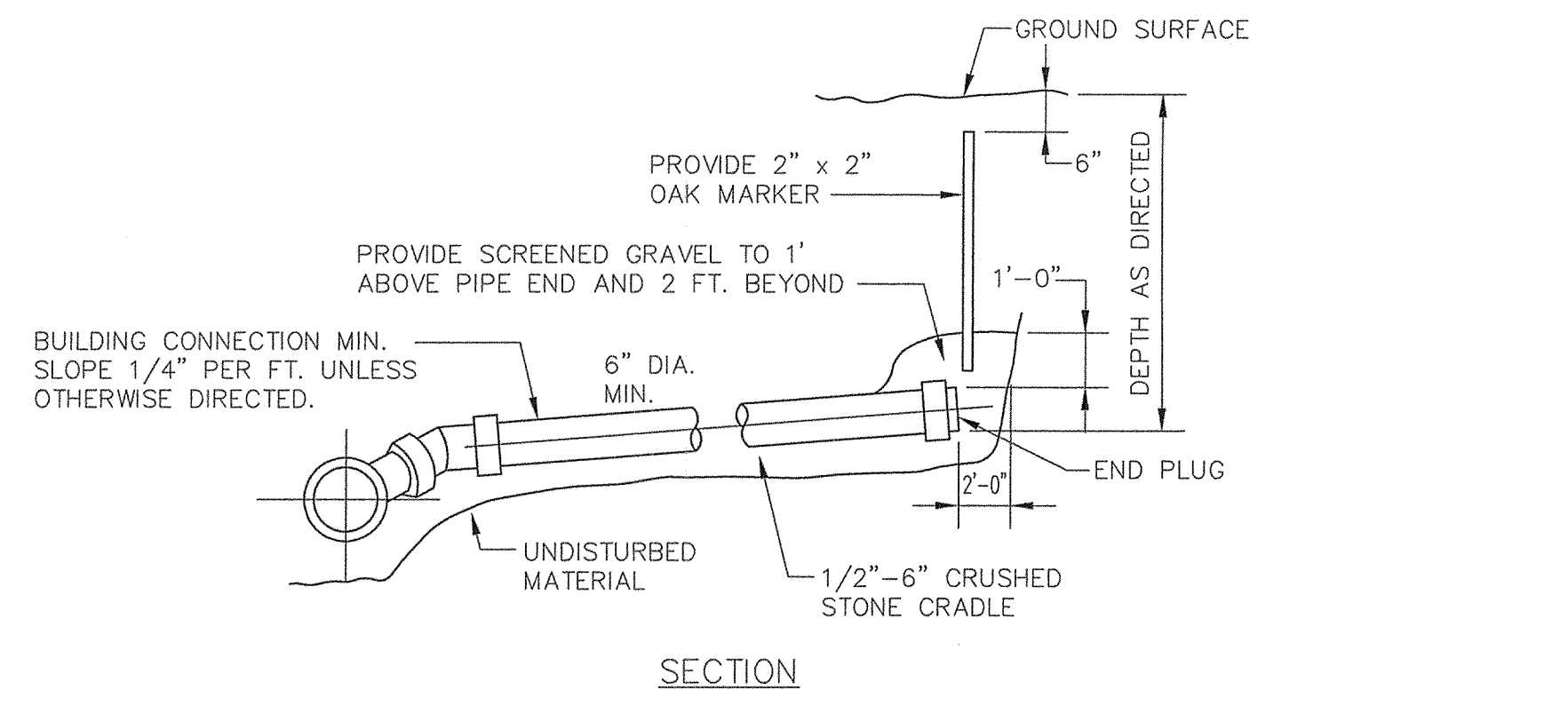

TYPICAL BUILDING CONNECTION
NOT TO SCALE

TRENCH WIDTH (W)		
D	W	W
DIAMETER OF PIPE	UNSHEETED	SHEETED
TO 12"	3'	4'
14" TO 24"	4'	5'
30" TO 36"	5'	6'

PROVIDE DETECTABLE WARNING TAPE OVER ALL SEWER LINES, FORCE MAINS, AND SEWER SERVICES.

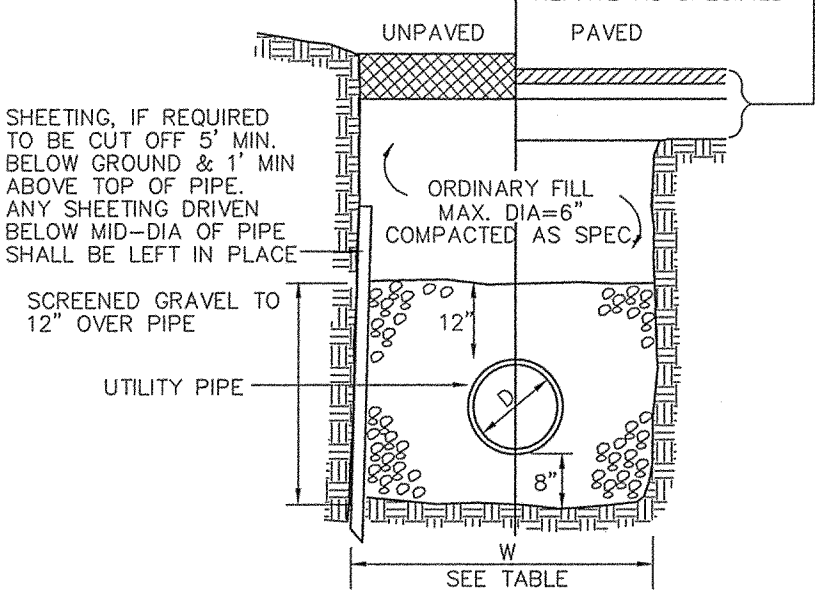

TYPICAL TRENCH DETAIL
NOT TO SCALE

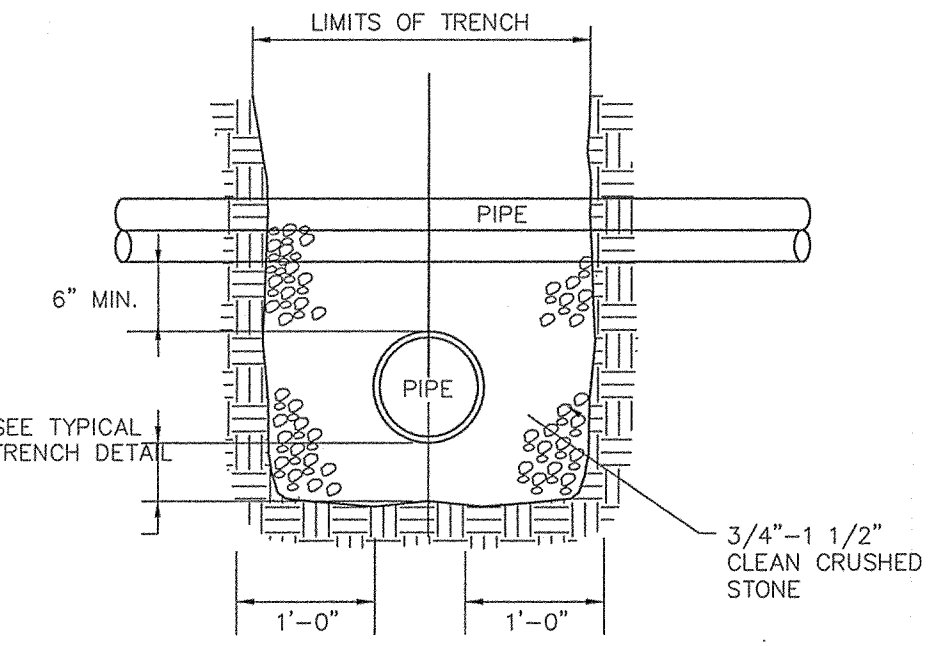

NOTE: FOR WATER AND SEWER CROSSINGS MAINTAIN 18 INCHES OF SEPARATION BETWEEN PIPES. LAY PIPES SUCH THAT CONNECTION JOINTS ARE 10 FEET EITHER SIDE OF THE CROSSING. ALL WATER PIPES LAID OVER SEWER PIPES. SEWER PIPE SHALL BE CLASS 150 PRESSURE PIPE.

UTILITY CROSSING DETAIL
NOT TO SCALE

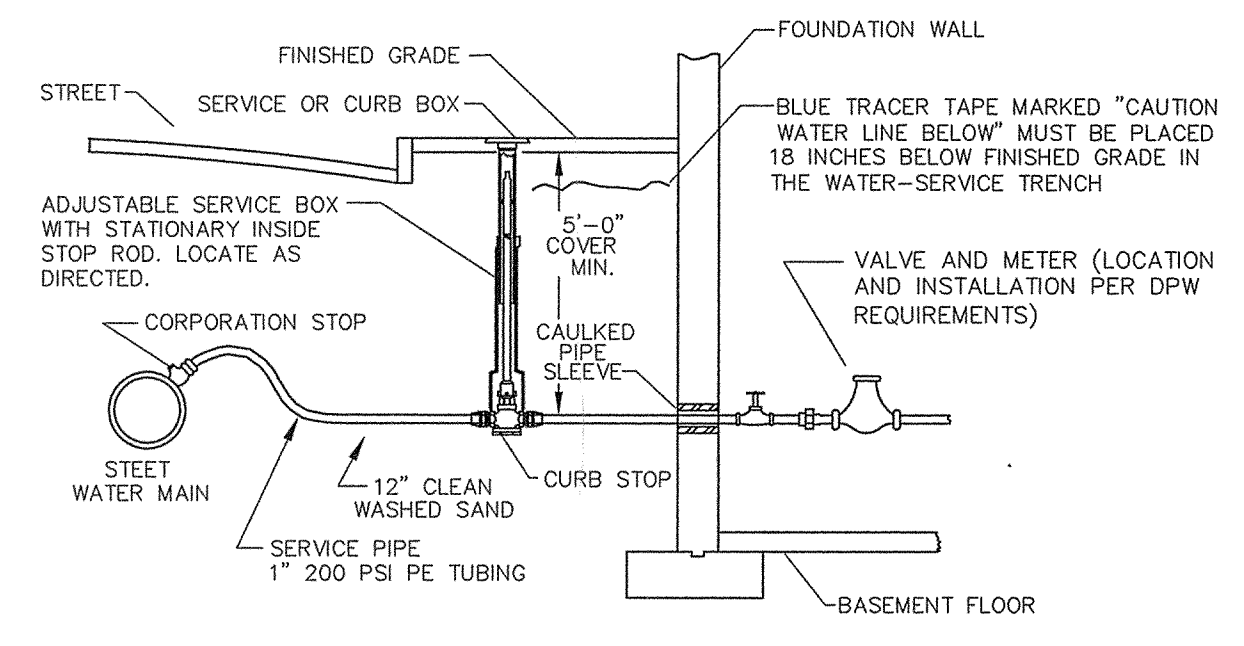

NOTES:
1. PLASTIC 200 PSI TUBING SHALL MEET AWWA SPEC. AND BE 200 PSI (MIN.)
2. ALL CONSTRUCTION METHODS AND MATERIALS INCLUDING CURB STOP, CORPORATION STOP, SERVICE PIPE, SERVICE BOX, VALVES, AND METER SHALL BE IN ACCORDANCE WITH THE TOWN OF NORTHBOROUGH DPW STANDARDS AND SPECIFICATIONS.

TYPICAL WATER SERVICE CONNECTION
NOT TO SCALE

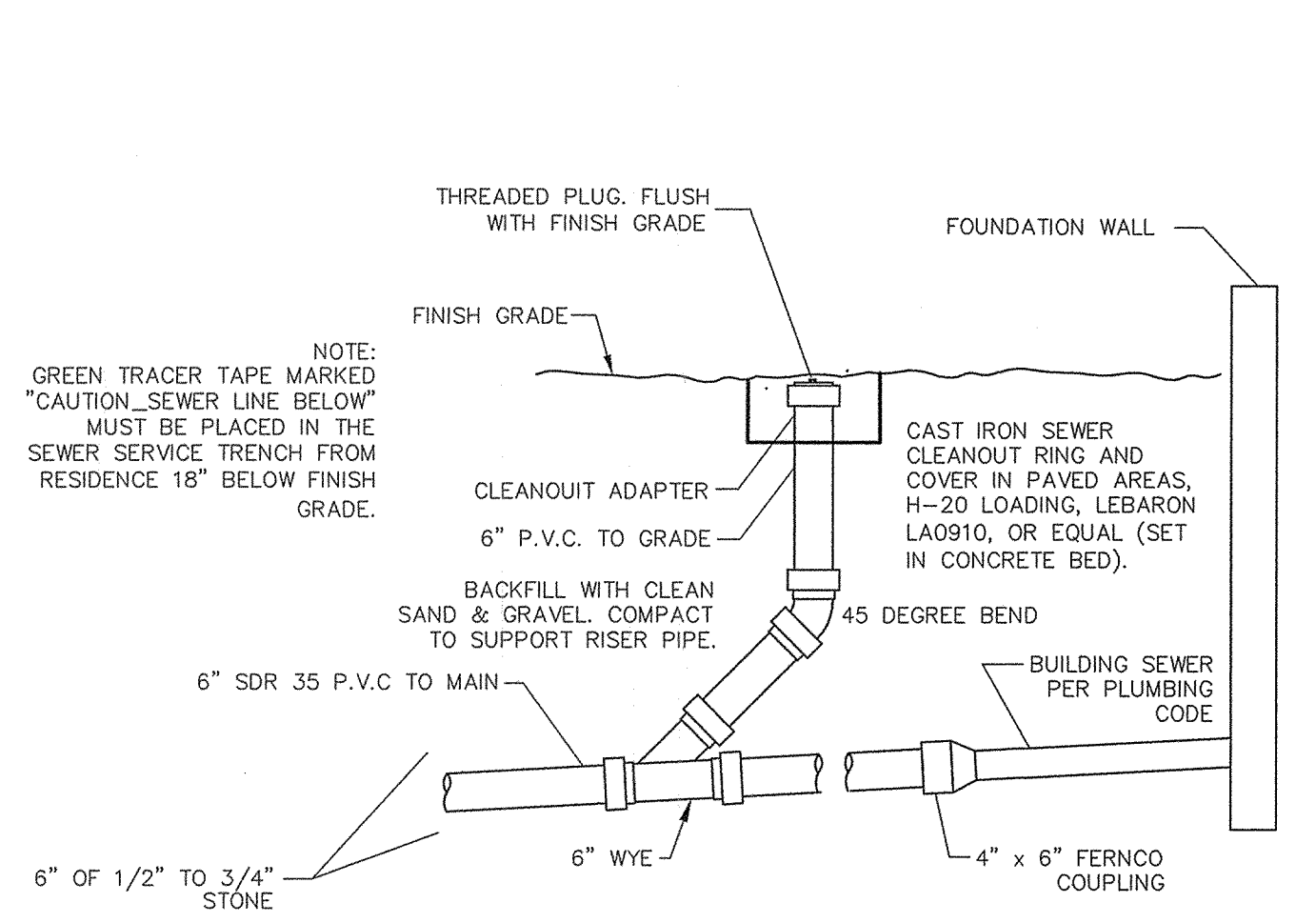

SEWER SERVICE LINES CLEANOUT & FITTINGS
NOT TO SCALE

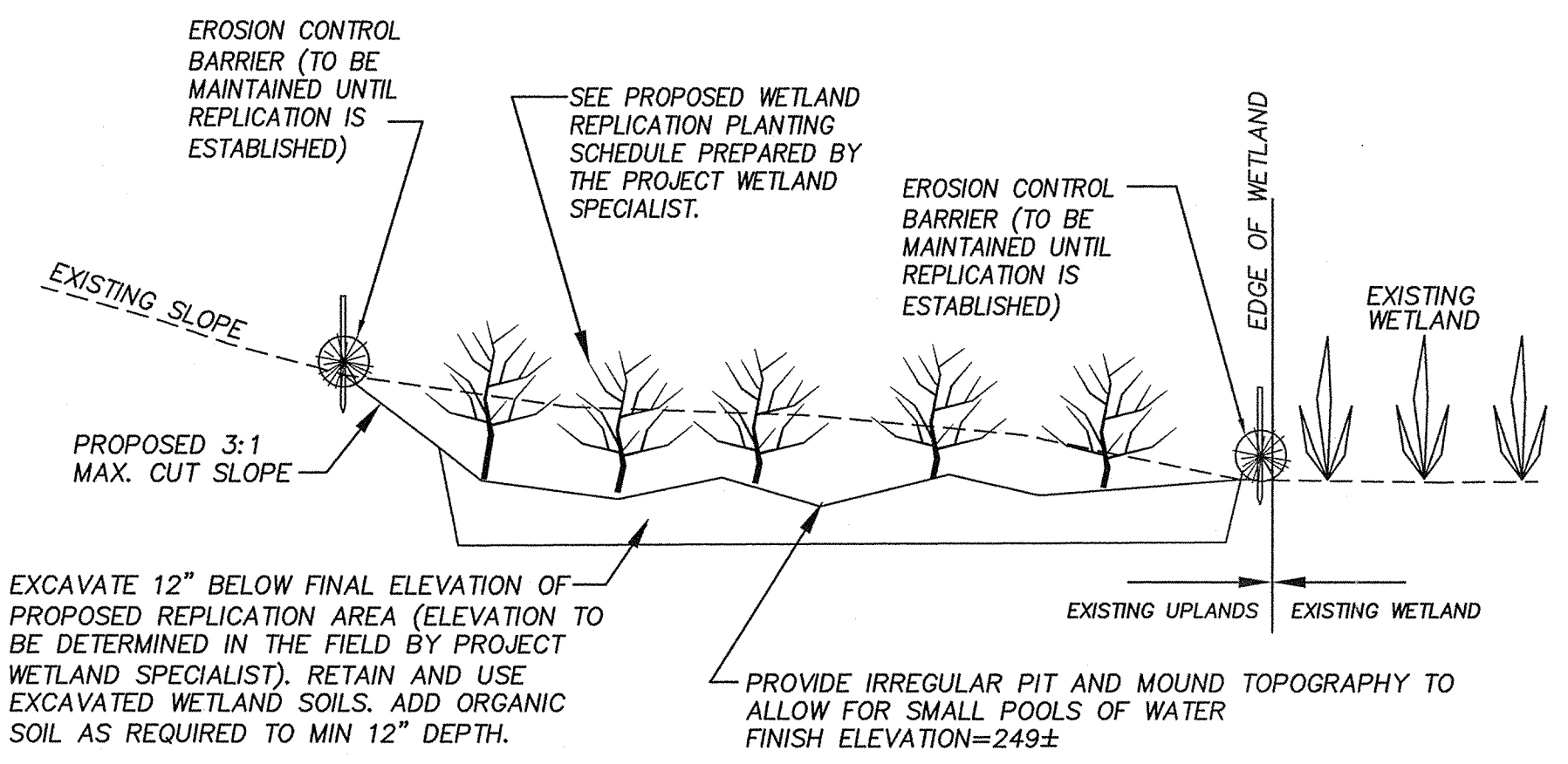

WETLAND REPLICATION AREA CROSS-SECTION
NOT TO SCALE

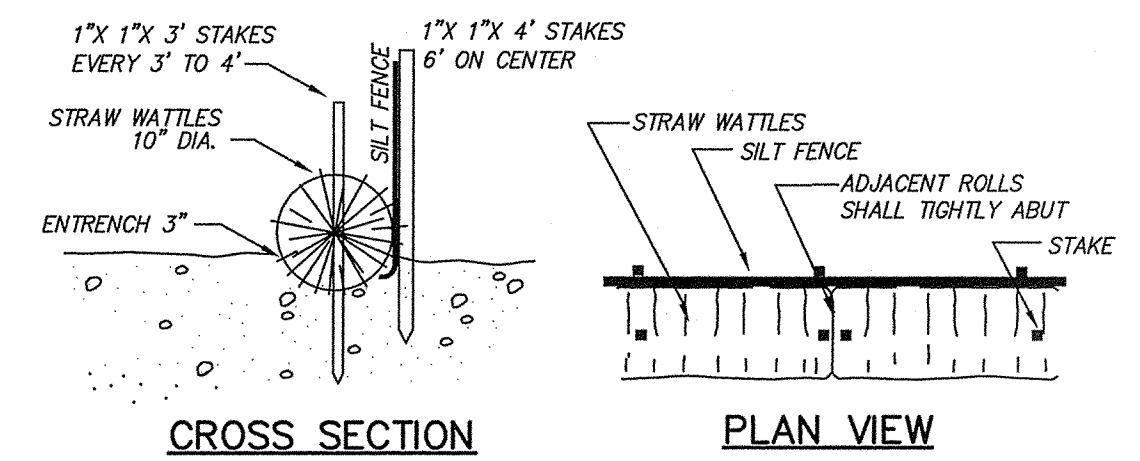

NOTES:
1. STRAW ROLL INSTALLATION REQUIRES THE PLACEMENT AND SECURE STAKING OF THE ROLL IN A TRENCH, 3\"/>

EROSION BARRIER
NOT TO SCALE

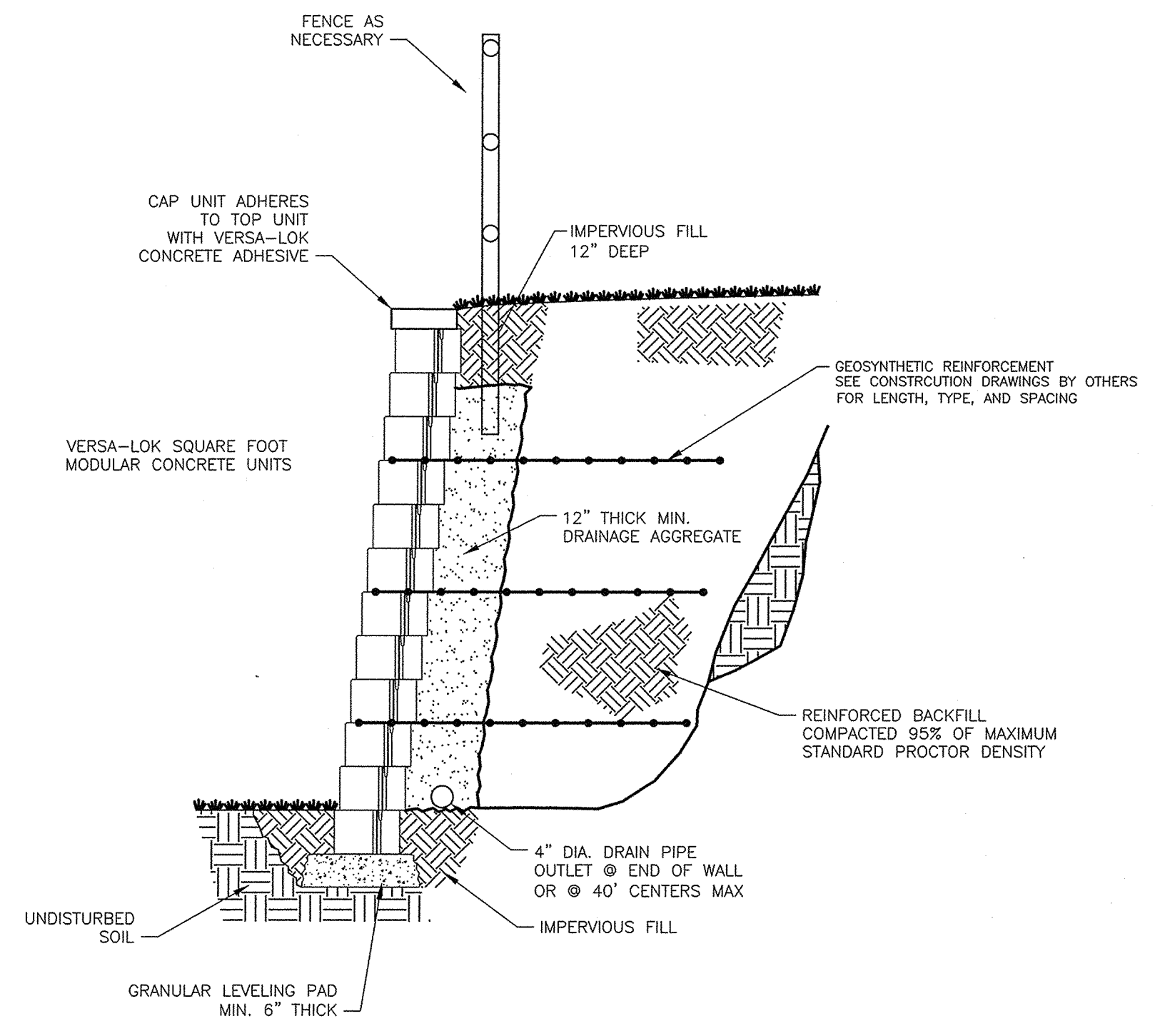

TYPICAL SECTION REINFORCED RETAINING WALL
SCALE: NONE

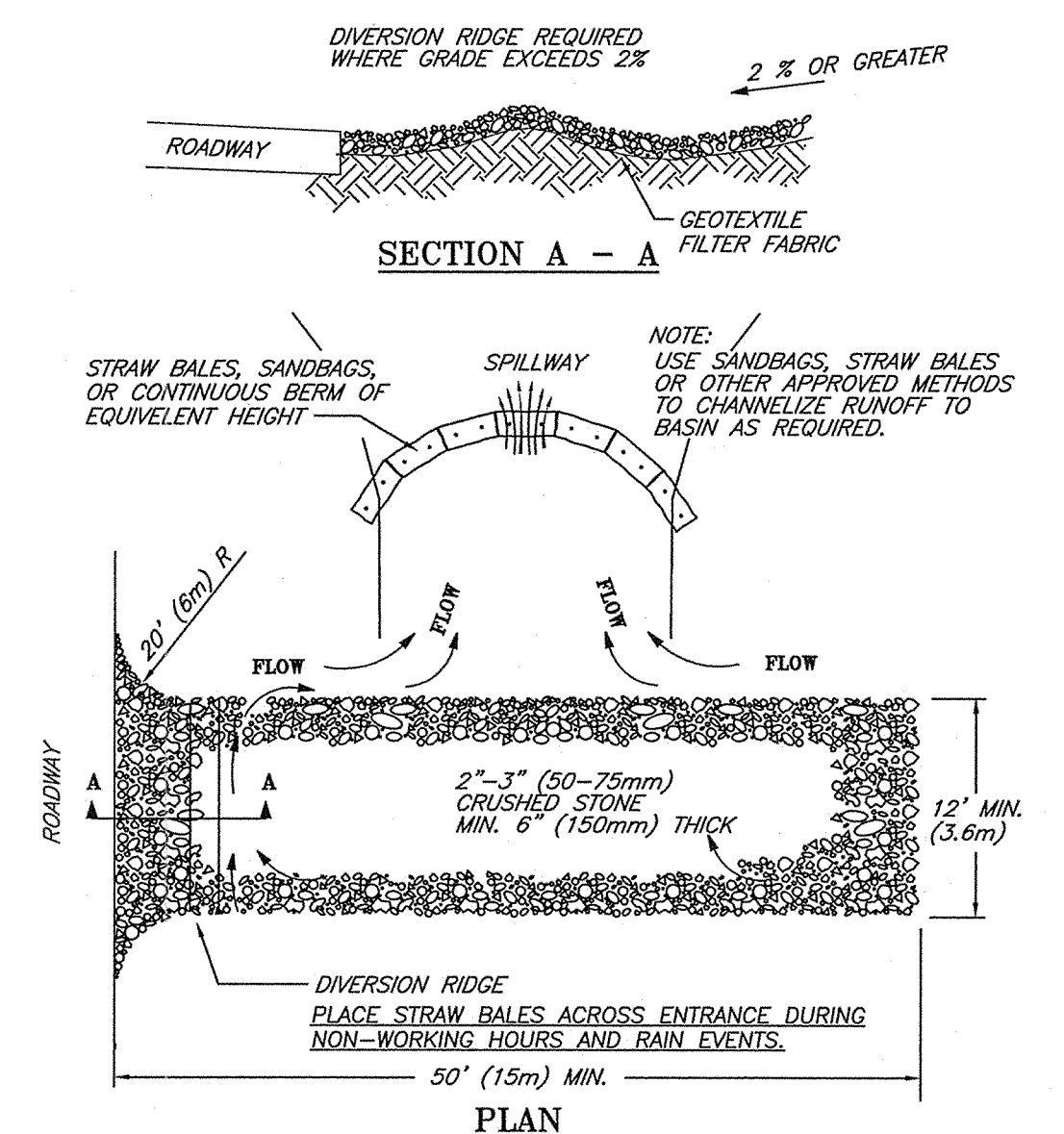

NOTES:
1. THE ENTRANCE SHALL BE MAINTAINED IN A CONDITION THAT WILL PREVENT TRACKING OR FLOWING OF SEDIMENT ONTO PUBLIC RIGHT-OF-WAYS. THIS MAY REQUIRE TOP DRESSING, REPAIR AND/OR CLEANOUT OF ANY MEASURES USED TO TRAP SEDIMENT.
2. WHEN NECESSARY, WHEELS SHALL BE CLEANED PRIOR TO ENTRANCE ONTO PUBLIC RIGHT-OF-WAY.
3. WHEN WASHING IS REQUIRED, IT SHALL BE DONE ON AN AREA STABILIZED WITH CRUSHED STONE THAT DRAINS INTO AN APPROVED SEDIMENT TRAP OR SEDIMENT BASIN.
4. STONE APRON SHALL BE REPLACED AS DEPOSITED SOILS BUILD UP.

TEMPORARY GRAVEL CONSTRUCTION ENTRANCE/EXIT
© 1994 JOHN MCCULLAN

EROSION AND SEDIMENTATION CONTROL NOTES:

- ALL WORK SHALL BE IN ACCORDANCE WITH THE PLANS AND PERMIT CONDITIONS.
- PRIOR TO INITIATING CONSTRUCTION, ALL SEDIMENTATION AND EROSION CONTROL MEASURES SHALL BE INSTALLED AS SHOWN ON THE PLANS AND DETAIL DRAWINGS.
- THIS PLAN DEPICTS THE MINIMUM REQUIRED SEDIMENTATION AND EROSION CONTROLS. THE CONTRACTOR SHALL EMPLOY ADDITIONAL SEDIMENTATION AND EROSION CONTROL MEASURES AS NECESSITATED BY SITE CONDITIONS, OR AS DIRECTED BY THE OWNER, THE OWNER'S REPRESENTATIVE, OR THE CONSERVATION COMMISSION TO ENSURE PROTECTION OF ALL WETLAND RESOURCES AND CONTROL SEDIMENT TRANSPORT. IF SEDIMENTATION PLUMES OCCUR, THE CONTRACTOR SHALL STOP WORK AND INSTALL ADDITIONAL SEDIMENTATION CONTROL DEVICES IMMEDIATELY TO PREVENT FURTHER SEDIMENTATION.
- THE CONTRACTOR SHALL BE RESPONSIBLE FOR MAINTAINING ALL TEMPORARY AND PERMANENT SEDIMENTATION AND EROSION CONTROLS UNTIL WORK IS COMPLETE AND ALL AREAS HAVE BEEN PERMANENTLY STABILIZED. AT SUCH TIME THE CONTRACTOR IS RESPONSIBLE FOR REMOVING ALL SEDIMENTATION AND EROSION CONTROL MEASURES.
- THE CONTRACTOR SHALL INSPECT SEDIMENTATION AND EROSION CONTROLS ON A DAILY BASIS AND IMMEDIATELY AFTER EACH RAINFALL; REPAIRS SHALL BE MADE BY THE END OF THE WORKING DAY. ACCUMULATED SEDIMENT SHALL BE REMOVED AND DISPOSED OF BY THE CONTRACTOR WHEN THE VOLUME REACHES 1/4 TO 1/2 THE HEIGHT OF SILT FENCE OR SEDIMENT TRAP, OR AS DIRECTED BY THE LOCAL AUTHORITY.
- SOIL STOCKPILES SHALL BE STABILIZED TO PREVENT EROSION, AND A PERIMETER SEDIMENT CONTROL SYSTEM SHALL BE INSTALLED. NO MATERIALS SUBJECT TO EROSION SHALL BE STOCKPILED OVERNIGHT WITHIN 100 FEET OF A WETLAND UNLESS COVERED.
- DISTURBED AREAS SHALL BE STABILIZED BY LOAMING AND SEEDING, OR BY ANOTHER APPROVED METHOD, AS SOON AS POSSIBLE AFTER THE FINISHED GRADE HAS BEEN MET. DISTURBED AREAS WITH SLOPES 3:1 (H:V) OR GREATER SHALL BE COVERED WITH LOAM AND STABILIZED WITH HYDROSEED AND SOIL TACKIFIER. IF FINAL GRADING DOES NOT OCCUR DURING THE GROWING SEASON, THESE AREAS SHALL BE MULCHED WITH HAY SECURED.
- DEWATERING OPERATIONS, IF REQUIRED, SHALL DISCHARGE ONTO STABILIZED AREAS, AND ALL DISCHARGE WATER IS TO PASS THROUGH SEDIMENTATION CONTROL DEVICES TO PREVENT IMPACTS UPON WATER BODIES, BORDERING VEGETATED WETLANDS, DRAINAGE SYSTEMS AND ADJUTING PROPERTIES. AT A MINIMUM ALL DISCHARGES SHALL BE INTERCEPTED BY HAYBALE CORRAL AND HAYBALE CHECK DAMS SPACED 10' APART.
- STAKED WATTLES AND SILT FENCE SHALL BE INSTALLED ALONG THE EDGE OF PROPOSED DEVELOPMENT OR AS INDICATED ON THE PLANS. ADDITIONAL WATTLES AND SILT FENCE SHALL BE LOCATED AS CONDITIONS WARRANT, AND IN SOME AREAS STRUCTURES MAY HAVE TO BE DUPLICATED AT REGULAR INTERVALS.
- STREET SWEEPING IN THE VICINITY OF THE PROJECT AREA SHALL BE PERFORMED AS NEEDED UNTIL THE PROJECT LIMITS HAVE BEEN STABILIZED. ALL SEDIMENT TRACKED ONTO PUBLIC RIGHT-OF-WAYS SHALL BE SWEEPED AT THE END OF EACH WORKING DAY.
- ALL EXISTING AND PROPOSED DRAINAGE SYSTEM INLETS, WHICH MAY RECEIVE STORMWATER FLOW FROM DISTURBED AREAS, SHALL BE PROVIDED WITH SILT SACKS. THE CONTRACTOR SHALL MAINTAIN THESE DEVICES PER THE MANUFACTURER'S RECOMMENDATIONS UNTIL ALL WORK IS COMPLETED AND ALL AREAS HAVE BEEN ADEQUATELY STABILIZED.
- DUST CONTROL MEASURES SHALL BE IMPLEMENTED AND MAINTAINED PROPERLY THROUGHOUT DRY WEATHER PERIODS UNTIL ALL DISTURBED AREAS HAVE BEEN PERMANENTLY STABILIZED. METHODS FOR DUST CONTROL SHALL INCLUDE WATER SPRINKLING AND/OR OTHER METHODS APPROVED BY THE ENGINEER.
- ALL VEHICLES SHALL ENTER AND EXIT THE SITE VIA THE STABILIZED CONSTRUCTION ENTRANCE CONSISTING OF CRUSHED STONE TO A DEPTH OF 6\"/>



OWNER / APPLICANT:
CIRCLE ASSETS, LLC
291 MAIN STREET, SUITE 8
NORTHBOROUGH, MA

CONNORSTONE ENGINEERING INC.
CIVIL ENGINEERS AND LAND SURVEYORS
10 SOUTHWEST CUTOFF, SUITE 7
NORTHBOROUGH, MASSACHUSETTS 01532
PHONE: 508-393-9727 FAX: 508-393-5242

CONSTRUCTION DETAILS OF 100 HUDSON STREET IN NORTHBOROUGH, MA

REVISED:	DESCRIPTION:
DRAWN BY: REM	CHECK BY: VC
DATE: DECEMBER 24, 2020	
SCALE: 1"=20' SHEET 3 OF 3.	

